



A PERFECT ENVIRONMENT

Residential Recreational Responsible

Chair
Ron Troy
Supervisors
Edward Kranick
Christie Dionisopoulos
Steve Michels
Joe Woelfle
Clerk/Treasurer
Dan Green

**TOWN OF DELAFIELD BOARD OF SUPERVISORS MEETING
TUESDAY, AUGUST 24, 2021 – 6:30 P.M.
DELAFIELD TOWN HALL – W302 N1254 MAPLE AVENUE, DELAFIELD, WI**

AGENDA

1. Call to Order
2. Pledge of Allegiance
3. Roll Call
4. Citizen Comments: Public comments from citizens regarding items on, or not on the Agenda. The Board may not engage in a discussion with the citizen making the comments. Individual presentations are limited to three minutes and citizens shall follow the rules set forth in Section 2.04(1)(d) of the Town Code.
5. Approval of Minutes:
 - A. August 10, 2021 Town Board Minutes
6. Action on vouchers submitted for payment:
 - A. Report on budget sub-accounts and action to amend 2021 budget
 - B. 1) Accounts payable; 2) Payroll
7. Communications (for discussion and possible action)
 - A. Waste Hauler Services – Waukesha County RFP process (Discussion only)
 - B. Redistricting Update
 - C. Safebuilt Quarterly Report
 - D. Upcoming Plan Commission Item: Car dealership near Hwy 16 on Lynndale Road. (Discussion only)
 - E. Lake Country Fire and Rescue 2022 Budget (Discussion only)
8. Unfinished Business - None
9. New Business
 - A. Discussion and possible action on the adoption of Ordinance 2021-09, an ordinance to repeal and re-create portion of Chapter 8 of the Town Code.
 - B. Discussion and possible action on a 3-year service contract with Shawn's Deer Pick Up for deer removal services.
10. Announcements and Planning items
 - A. Plan Commission – Tuesday, September 7, 2021 @ 6:30 PM
 - B. Budget Workshop – Tuesday, September 14, 2021 @ 5:00 PM
 - C. Town Board – Tuesday, September 14, 2021 @ Immediately following the Budget Workshop
11. Adjournment

Daniel Green

Dan Green
Town of Delafield Clerk/Treasurer

PLEASE NOTE:

- ✓ It is possible that action will be taken on any of the items on the agenda and that the agenda may be discussed in any order. It is also possible that a quorum of other governmental bodies of the municipality may be in attendance at the above-stated meeting to gather information; no action will be taken by any governmental body at the above-stated meeting other than the governmental body specifically referred to above in this notice.
- ✓ Also, upon reasonable notice, efforts will be made to accommodate the needs of disabled individuals through appropriate aids and services. For additional information or to request this service, contact Town Clerk Dan Green (262) 646-2398.

**TOWN OF DELAFIELD BOARD OF SUPERVISORS MEETING
AUGUST 10, 2021 @ 6:30 PM**

Video Link: <https://www.youtube.com/watch?v=1FVDKbBlyQQ>

First order of business: Call to Order
Chairman Troy called the meeting to order at 6:30 p.m.

Second order of business: Pledge of Allegiance

Third order of business: Roll Call

Present: Chairman Troy, Supervisor Dionisopoulos, Supervisor Kranick and Supervisor Michels. Also, present was Administrator Dan Green.

Excused: Supervisor Woelfle

Fourth order of business: Citizen Comments:

Jon Spheeris, S1W33857 Abitz Road, stated he is looking for an early start permit for The Retreat Subdivision. He explained he has started early in other communities to help stabilize the soil before September 15th. He is working on the letter of credit and the bond required by Waukesha County.

Fifth order of business:

- A. Approval of July 27, 2021, Town Board Minutes

Motion made by Supervisor Kranick to approve the minutes from July 27, 2021. Seconded by Supervisor Michels. Motion passed 4-0.

Sixth order of Business: Action on vouchers submitted for payment:

- A. Report on budget sub-accounts and action to amend 2021 budget
B. 1) Accounts payable; 2) Payroll

Motion by Supervisor Kranick to approve payment of Checks #64916-#64917 and checks #64921-#64942 in the amount of \$99,249.07 and payrolls dated August 6, 2021, in the amount of \$14,039.86. Seconded by Supervisor Dionisopoulos. Motion passed 4-0.

Seventh order of Business: Communications (*for discussion and possible action*) - None

- A. Waste Hauler Services – Waukesha County RFP process (Discussion only)
Administrator Green explained that the County will be sending out the RFP next week and the final scores (results) to the municipalities in early October.
- B. Redistricting Update
Administrator Green explained that the County hosted a meeting last week, to demonstrate the mapping software the County uses for drawing district boundaries. Once the final census numbers are in, the communities can draw their new lines.
- C. Lake Country Fire and Rescue Budget (Discussion Only)
Supervisor Michels stated that last Thursday, the Lake Country Board met for the first budget workshop. The first draft of the budget was presented by Chief Fennig. The board meets next Thursday for another budget session. Supervisor Michels explained the board previously had a series of meetings regarding an employee who did not obey LCFR's policies, and resigned from his position. The new budget reflects an increase in legal fees, and the cost of paying the employee's severance package.

Supervisor Michels also explained that there is an effort to unionize Lake Country Fire and Rescue. They have applied for unionization and have submitted ballots.

Supervisor Michels explained that as far as the budget goes, the Chief is recommending 5.14% increase for 2022 (the maximum allowable levy increase). He explained that the Fire Chief stated to remain operational, with a 3% increase in wages, and insurance, the budget would need to be increased by 3.14%. The other 2% would be to add 3 new full-time staff. These staff members would be to add a 12th person on each shift, to cover for sick and vacation days.

Chairman Troy asked what the reaction was from the other communities to a 5.14% increase. Supervisor Michels stated that he and Mr. Arbucias expressed concern about the increase, as did the City of Delafield and Village of Nashotah. He stated that the capital budget would also be increased by 5%. He explained that the Fire Chief assured the board that a 1% increase in wages only equated to \$16,000 in the budget, and it might not be the most pertinent place to find cost savings.

Supervisor Kranick stated there are still a lot of hoops to go through before the budget is final, and the Lake Country Board still has work to do before it is final. He also explained that if one municipality does not adopt the budget, it goes back to the prior year's budget.

Chairman Troy questions if the department was currently in the process of unionizing, and if it could be decided by the fall. Supervisor Michels stated it is possible, but that negotiations for salaries can often take 1 to 3 years. He did suggest increasing their legal fees to a higher amount than \$10,000 for union negotiations.

Eighth order of Business: Unfinished Business: NONE

Ninth order of Business: New Business:

- A. Discussion and possible action on the request from Jon Spheeris for an early start approval for the Retreat Subdivision.

Engineer Barbeau explained this subdivision is off Norms Road. It is an 8-lot subdivision, with one home already existing. He explained the owner has signed the Developer's Agreement, and a final plat is currently in review by the State and County. He explained the developer has a draft form for the letter of credit, and it will be ready to go as soon as the bank signs it. Engineer Barbeau stated the reason for starting now, is to get the work done to get the property restored before the fall comes. He explained that typically the Developer's Agreement and the Letter of Credit come before the start of construction. Staff recommends approval of starting early so long as the Letter of Credit is given to the Administrator prior to beginning work.

Motion by Supervisor Kranick to approve the early start for Jon Spheeris for the Retreat Subdivision contingent on the Letter of Credit being filed with the Administrator. Seconded by Supervisor Dionisopoulos. Motion passed 4-0.

- B. Discussion and possible action on the adoption of Ordinance 2021-06, an ordinance to repeal and re-create portions of Chapter 19 of the Town Code concerning regulations of parks.

Administrator Green explained this ordinance helps to enforce dog regulations in the parks, updates the old version by removing references to the Park Commission, and has other small changes like park hours, drone usage, and staff titles. The board had questions regarding the regulations of drones, the new time for park closures and adding language that distinguishes Town parks from County/State parks.

Motion by Supervisor Kranick to approve Ordinance 2021-06, an ordinance to repeal and recreate portions of Chapter 19 of the Town Code concerning regulations of parks. Seconded by Supervisor Michels. Motion passed 4-0.

- C. Discussion and possible action on the adoption of Ordinance 2021-07, an ordinance granting limited expenditure, contracting and contract execution authority to the Town Administrator/Clerk/Treasurer and Town Chair.

Chairman Troy explained this ordinance is to give the Town Chair and the Town Administrator the power to make purchases of up to \$25,000, in the case of an emergency. An example of such a case was when the chiller in the IT room broke. He also explained this ordinance will allow the Town to act on Ordinance 2021-08 regarding meeting cancellations.

Motion by Supervisor Kranick to adopt Ordinance 2021-07, an ordinance granting limited expenditure, contracting and contract execution authority to the Town Administrator/Clerk/Treasurer and Town Chair. Seconded by Supervisor Michels. Motion passed 4-0.

- D. Discussion and possible action on the adoption of Ordinance 2021-08, an ordinance granting the Town Chair or the Town Board the authority to cancel a meeting of the Town Board.

Motion by Supervisor Michels to approve Ordinance 2021-08, an ordinance granting the Town Chair or the Town Board the authority to cancel a meeting of the Town Board. Seconded by Supervisor Dionisopoulos. Motion passed 4-0.

- E. Discussion and possible action on updates to the Town's employee handbook.

Chairman Troy explained the last handbook was updated in 2016. This version removes the fire department, makes updates to the computer use/IT policy, and updates procedures with the Town now having an administrator.

Motion by Supervisor Kranick to approve the updates to the Town's employee handbook, subject to the removal of liaison references and updating "Chairman" to "Chair". Seconded by Supervisor Dionisopoulos. Motion passed 4-0.

Tenth order of Business: Announcements and Planning items

- A. Town Board – Tuesday, August 24, 2021 @ 6:30 PM
- B. Plan Commission – Tuesday, September 7, 2021 @ 6:30 PM
- C. Budget Workshop – Tuesday, September 14, 2021 @ 5:00 PM
- D. Town Board – Tuesday, September 14, 2021 – Immediately following the Budget Workshop

Eleventh order of Business: Adjournment

Motion by Supervisor Kranick to adjourn the August 10, 2021, Town Board meeting at 7:18 p.m. Seconded by Supervisor Michels. Motion carried 4-0.

Respectfully submitted:

Dan Green, CMC/WCMC
Administrator - Town Clerk/Treasurer

TOWN OF DELAFIELD
GENERAL FUND
STATEMENT OF REVENUES COMPARED TO BUDGET
August 31, 2021

	<u>Current Month</u>	<u>Year To Date</u>	<u>Annual Budget</u>	<u>Variance</u>	
<u>TAXES</u>					
10-41110	PROPERTY TAX	1,786,527.20	1,786,527.20	\$ 1,786,527.00	0.20
10-41119	TAX ROLL OVERRUN (U	(0.11)	(0.11)	0.00	(0.11)
10-41150	MANAGED FOREST LAN	144.56	144.56	144.00	0.56
10-41220	SALES TAX DISCOUNT	0.00	0.00	30.00	(30.00)
10-41900	LAND USE TAX PENALT	496.08	496.08	0.00	496.08
10-42000	SPECIAL ASSESSMENTS-	0.00	0.00	8,571.00	(8,571.00)
		<hr/>	<hr/>	<hr/>	<hr/>
		1,787,167.73	1,787,167.73	1,795,272.00	(8,104.27)
<u>INTERGOVERNMENTAL</u>					
10-43410	STATE SHARED REVENU	15,222.30	15,222.30	101,481.00	(86,258.70)
10-43415	PERSONAL PROPERTY T	4,072.06	4,072.06	4,072.00	0.06
10-43521	LAKE PATROL AIDS	0.00	0.00	14,579.00	(14,579.00)
10-43531	HIGHWAY AIDS	99,943.22	99,943.22	200,149.00	(100,205.78)
10-43533	COMPUTER AID	508.20	508.20	508.00	0.20
10-43610	SERVICES TO WISCONSI	7,100.63	7,100.63	10,700.00	(3,599.37)
10-43620	PAYMENT IN LIEU OF TA	5,912.69	5,912.69	5,640.00	272.69
10-43630	VIDEO SERVICE PROVID	24,470.74	24,470.74	24,471.00	(0.26)
		<hr/>	<hr/>	<hr/>	<hr/>
		157,229.84	157,229.84	361,600.00	(204,370.16)
<u>LICENSES & PERMITS</u>					
10-44110	LIQUOR LICENSES	1,390.00	1,390.00	1,400.00	(10.00)
10-44120	OPERATOR LICENSES	0.00	0.00	825.00	(825.00)
10-44122	SODA LICENSES	15.00	15.00	35.00	(20.00)
10-44124	CABLE TV FRANCHISE F	23,190.24	23,190.24	45,529.00	(22,338.76)
10-44210	DOG LICENSES	2,062.63	2,062.63	3,300.00	(1,237.37)
10-44220	OTHER LICENSES	200.00	200.00	300.00	(100.00)
10-44310	BUILDING PERMITS	91,291.97	91,291.97	115,000.00	(23,708.03)
10-44312	TEMPORARY OCCUPAN	0.00	0.00	500.00	(500.00)
10-44313	INSPECTION PLAN REVI	3,102.25	3,102.25	5,500.00	(2,397.75)
10-44315	BUILDING REINSPECTIO	0.00	0.00	500.00	(500.00)
10-44320	ELECTRICAL PERMITS	22,071.34	22,071.34	35,000.00	(12,928.66)
10-44330	HEATING PERMITS	18,637.06	18,637.06	30,000.00	(11,362.94)
10-44340	PLUMBING PERMITS	14,560.76	14,560.76	30,000.00	(15,439.24)
10-44370	ZONING PERMIT	8,210.75	8,210.75	12,000.00	(3,789.25)
10-44380	WI STATE PERMIT SEAL	690.00	690.00	1,000.00	(310.00)
10-44390	CONCRETE DRIVE PERM	350.00	350.00	1,000.00	(650.00)
10-44400	RIGHT OF WAY PERMITS	1,700.00	1,700.00	1,500.00	200.00
		<hr/>	<hr/>	<hr/>	<hr/>
		187,472.00	187,472.00	283,389.00	(95,917.00)
<u>FINES, PENALTIES & JUDGMENTS</u>					
10-45110	COURT FINES	15,660.17	15,660.17	12,500.00	3,160.17
10-45120	PARKING TICKETS	435.00	435.00	2,500.00	(2,065.00)
		<hr/>	<hr/>	<hr/>	<hr/>
		16,095.17	16,095.17	15,000.00	1,095.17

TOWN OF DELAFIELD
GENERAL FUND
STATEMENT OF REVENUES COMPARED TO BUDGET
August 31, 2021

	<u>Current Month</u>	<u>Year To Date</u>	<u>Annual Budget</u>	<u>Variance</u>
<u>CHARGES FOR SERVICES</u>				
10-46101 SALE OF MAPS, CODE B	5.25	5.25	100.00	(94.75)
10-46103 PUBLIC HEARING	2,463.00	2,463.00	2,500.00	(37.00)
10-46104 HOUSE NUMBERS	334.00	334.00	150.00	184.00
10-46105 ENGINEERING REVIEW F	465.00	465.00	1,200.00	(735.00)
10-46121 TAX SEARCH	1,655.00	1,655.00	500.00	1,155.00
10-46199 OTHER CHARGES FOR S	0.00	0.00	150.00	(150.00)
10-46220 FIRE RUNS	150.00	150.00	0.00	150.00
10-46230 AMBULANCE FEE	16,828.68	16,828.68	0.00	16,828.68
10-46310 SALE OF HIGHWAY MAT	2,610.00	2,610.00	12,000.00	(9,390.00)
10-46420 REFUSE COLLECTION	670,524.00	670,524.00	673,400.00	(2,876.00)
10-46730 PARK RESERVATION FE	5,851.28	5,851.28	5,000.00	851.28
10-46740 LITTLE LEAGUE BREWE	0.00	0.00	3,000.00	(3,000.00)
10-46750 RECREATION FEES-BASE	18,766.12	18,766.12	14,000.00	4,766.12
	<u>719,652.33</u>	<u>719,652.33</u>	<u>712,000.00</u>	<u>7,652.33</u>
<u>CONSERVATION & DEVELOPMENT</u>				
10-46841 LEGAL FEES - REIMBURS	76.00	76.00	7,000.00	(6,924.00)
10-46842 ENGINEERING - REIMBU	3,789.25	3,789.25	20,000.00	(16,210.75)
	<u>3,865.25</u>	<u>3,865.25</u>	<u>27,000.00</u>	<u>(23,134.75)</u>
<u>INTEREST</u>				
10-48110 INTEREST ON INVESTME	1,058.33	1,058.33	26,000.00	(24,941.67)
10-48136 INTEREST-SPECIAL ASSE	0.00	0.00	1,000.00	(1,000.00)
	<u>1,058.33</u>	<u>1,058.33</u>	<u>27,000.00</u>	<u>(25,941.67)</u>
<u>MISCELLANEOUS</u>				
10-48302 SALE OF ASSETS: FIRE	19,750.00	19,750.00	0.00	19,750.00
10-48309 SALE OF ASSETS: OTHE	2,500.00	2,500.00	0.00	2,500.00
10-48310 LEASE OF BUILDING/EQ	18,002.00	18,002.00	0.00	18,002.00
10-48440 INSURANCE CLAIMS: O	2,019.20	2,019.20	0.00	2,019.20
10-48520 TEAMS SPONSORS	11,225.00	11,225.00	7,500.00	3,725.00
10-49110 PROCEEDS OF LONG TER	561,000.00	561,000.00	561,000.00	0.00
10-49900 SUNDRY REVENUES	8.40	8.40	1,500.00	(1,491.60)
	<u>614,504.60</u>	<u>614,504.60</u>	<u>570,000.00</u>	<u>44,504.60</u>
TOTAL REVENUES	<u><u>3,487,045.25</u></u>	<u><u>3,487,045.25</u></u>	<u><u>\$ 3,791,261.00</u></u>	<u><u>(304,215.75)</u></u>

TOWN OF DELAFIELD
General Fund - Statement of Expenditures
August 31, 2021

<u>24</u>		<u>Current Month</u>	<u>Year to Date</u>	<u>Annual Budget</u>	<u>Variance</u>
GENERAL GOVERNMENT					
TOWN BOARD					
10-51100-110	SALARIES: ELECTED OFF	21,759.13	21,759.13	35,000.00	13,240.87
10-51100-131	SOCIAL SECURITY	1,664.67	1,664.67	2,678.00	1,013.33
10-51100-320	DUES, MEMBERSHIPS,PU	3,424.75	3,424.75	4,276.00	851.25
10-51100-321	MEETINGS & CONVENTI	90.00	90.00	1,000.00	910.00
10-51100-330	MILEAGE REIMBURSEM	0.00	0.00	500.00	500.00
10-51100-390	OTHER SUPPLIES & EXP	6.00	6.00	1,000.00	994.00
10-51100-398	AWARDS	0.00	0.00	1,500.00	1,500.00
		<hr/>	<hr/>	<hr/>	<hr/>
		26,944.55	26,944.55	45,954.00	19,009.45
LEGAL FEES					
10-51300-210	LEGAL COUNSEL	20,964.02	20,964.02	45,000.00	24,035.98
10-51300-211	LEGAL FEES - REIMBURS	0.00	0.00	7,000.00	7,000.00
		<hr/>	<hr/>	<hr/>	<hr/>
		20,964.02	20,964.02	52,000.00	31,035.98
CLERK/TREASURER					
10-51420-110	SALARIES: APPOINTED O	46,240.97	46,240.97	74,675.00	28,434.03
10-51420-125	WAGES: PARTTIME	27,236.06	27,236.06	55,000.00	27,763.94
10-51420-128	WAGES: OVERTIME	17.01	17.01	0.00	(17.01)
10-51420-130	PERSONAL INSURANCE	6,224.97	6,224.97	7,448.00	1,223.03
10-51420-131	SOCIAL SECURITY	5,964.30	5,964.30	10,549.00	4,584.70
10-51420-150	RETIREMENT BENEFIT	5,086.47	5,086.47	8,214.00	3,127.53
10-51420-252	DATA PROCESSING-TAX	8,847.29	8,847.29	8,000.00	(847.29)
10-51420-310	OFFICE SUPPLIES	1,194.75	1,194.75	3,000.00	1,805.25
10-51420-311	POSTAGE	2,096.47	2,096.47	6,000.00	3,903.53
10-51420-313	LEGAL NOTICES	262.78	262.78	800.00	537.22
10-51420-320	DUES, MEMBERSHIPS,PU	240.00	240.00	800.00	560.00
10-51420-321	MEETINGS & CONVENTI	164.00	164.00	250.00	86.00
10-51420-322	TUITIONS	0.00	0.00	1,500.00	1,500.00
10-51420-330	MILEAGE REIMBURSEM	213.67	213.67	500.00	286.33
10-51420-390	OTHER SUPPLIES & EXP	814.00	814.00	1,500.00	686.00
		<hr/>	<hr/>	<hr/>	<hr/>
		104,602.74	104,602.74	178,236.00	73,633.26
ELECTIONS					
10-51440-125	WAGES: PARTTIME	5,365.50	5,365.50	8,500.00	3,134.50
10-51440-230	EQUIPMENT MAINTENA	1,339.00	1,339.00	1,300.00	(39.00)
10-51440-313	LEGAL NOTICES	25.86	25.86	100.00	74.14
10-51440-340	OPERATING EXPENSES	2,230.61	2,230.61	2,500.00	269.39
		<hr/>	<hr/>	<hr/>	<hr/>
		8,960.97	8,960.97	12,400.00	3,439.03

TOWN OF DELAFIELD
General Fund - Statement of Expenditures
August 31, 2021

<u>24</u>	<u>Current Month</u>	<u>Year to Date</u>	<u>Annual Budget</u>	<u>Variance</u>
ACCOUNTING				
10-51510-212 AUDIT	19,504.00	19,504.00	19,500.00	(4.00)
10-51510-213 ACCOUNTING ASSISTAN	5,731.00	5,731.00	18,000.00	12,269.00
10-51510-251 PAYROLL PROCESSING F	387.40	387.40	1,000.00	612.60
	<hr/>	<hr/>	<hr/>	<hr/>
	25,622.40	25,622.40	38,500.00	12,877.60
ASSESSOR				
10-51530-299 OTHER CONTRACTED SE	34,423.76	34,423.76	49,500.00	15,076.24
10-51530-390 OTHER SUPPLIES & EXP	0.00	0.00	362.00	362.00
	<hr/>	<hr/>	<hr/>	<hr/>
	34,423.76	34,423.76	49,862.00	15,438.24
TOWN HALL OPERATIONS				
10-51600-216 COMPUTER CONSULTAN	2,854.39	2,854.39	4,000.00	1,145.61
10-51600-217 WEB SITE DEVELOPMEN	2,250.00	2,250.00	2,250.00	0.00
10-51600-218 SOFTWARE SUPPORT	1,504.45	1,504.45	1,950.00	445.55
10-51600-220 NATURAL GAS	2,847.50	2,847.50	5,800.00	2,952.50
10-51600-221 ELECTRICITY	9,370.19	9,370.19	16,000.00	6,629.81
10-51600-222 TELEPHONE	10,904.18	10,904.18	21,000.00	10,095.82
10-51600-223 SANITATION	290.62	290.62	410.00	119.38
10-51600-350 BUILDING MAINTENANC	20,562.76	20,562.76	17,500.00	(3,062.76)
10-51600-360 EQUIPMENT LEASE	3,787.87	3,787.87	4,000.00	212.13
	<hr/>	<hr/>	<hr/>	<hr/>
	54,371.96	54,371.96	72,910.00	18,538.04
UNCOLLECTIBLE ACCOUNTS				
10-51910-743 ILLEGAL TAXES	3,483.93	3,483.93	0.00	(3,483.93)
	<hr/>	<hr/>	<hr/>	<hr/>
	3,483.93	3,483.93	0.00	(3,483.93)
INSURANCE				
10-51930-138 UNEMPLOYMENT COMP	331.25	331.25	1,000.00	668.75
10-51932-510 PROPERTY & LIABILITY	50,900.00	50,900.00	61,000.00	10,100.00
	<hr/>	<hr/>	<hr/>	<hr/>
	51,231.25	51,231.25	62,000.00	10,768.75
	<hr/>	<hr/>	<hr/>	<hr/>
TOTAL GENERAL GOVE	330,605.58	330,605.58	511,862.00	181,256.42
PUBLIC SAFETY				
LAW ENFORCEMENT				
10-52100-298 CONTRACTED OVERTIM	1,660.21	1,660.21	1,200.00	(460.21)
10-52100-299 OTHER CONTRACTED SE	45,705.78	45,705.78	60,941.00	15,235.22
10-52100-341 CITATION PROCESSING	1,020.09	1,020.09	1,900.00	879.91
10-52100-349 MISC OPERATING EXPEN	23.64	23.64	300.00	276.36
	<hr/>	<hr/>	<hr/>	<hr/>
	48,409.72	48,409.72	64,341.00	15,931.28
LAKE PATROL				
10-52110-296 LAKE PATROL	19,143.60	19,143.60	25,525.00	6,381.40
	<hr/>	<hr/>	<hr/>	<hr/>
	19,143.60	19,143.60	25,525.00	6,381.40

TOWN OF DELAFIELD
General Fund - Statement of Expenditures
August 31, 2021

<u>24</u>	<u>Current Month</u>	<u>Year to Date</u>	<u>Annual Budget</u>	<u>Variance</u>
FIRE DEPARTMENT ADMINISTRATION	0.00	0.00	0.00	0.00
FACILITIES	0.00	0.00	0.00	0.00
OPERATIONS				
10-52230-131 SOCIAL SECURITY	1,781.32	1,781.32	0.00	(1,781.32)
10-52230-341 UNIFORMS	(8.00)	(8.00)	0.00	8.00
	1,773.32	1,773.32	0.00	(1,773.32)

TOWN OF DELAFIELD
General Fund - Statement of Expenditures
August 31, 2021

<u>24</u>	<u>Current Month</u>	<u>Year to Date</u>	<u>Annual Budget</u>	<u>Variance</u>
FIRE PREVENTION	0.00	0.00	0.00	0.00
AMBULANCE & RESCUE				
10-52300-131 SOCIAL SECURITY	(1,702.16)	(1,702.16)	0.00	1,702.16
10-52300-230 EQUIPMENT MAINTENA	(2,908.50)	(2,908.50)	0.00	2,908.50
10-52300-290 EMS CONTRACTED SERV	1,082.01	1,082.01	0.00	(1,082.01)
10-52300-299 CONTRACTED SERVICES	641,655.73	641,655.73	640,127.00	(1,528.73)
	638,127.08	638,127.08	640,127.00	1,999.92
INSPECTION				
10-52400-299 OTHER CONTRACTED SE	80,540.79	80,540.79	148,525.00	67,984.21
10-52400-340 OTHER OPERATING SUP	1,324.71	1,324.71	2,500.00	1,175.29
	81,865.50	81,865.50	151,025.00	69,159.50
TOTAL PUBLIC SAFETY	789,319.22	789,319.22	881,018.00	91,698.78
PUBLIC WORKS				
TRANSPORATION				
BUILDING & GROUNDS OPERATIONS				
10-53270-220 NATURAL GAS	3,900.32	3,900.32	5,500.00	1,599.68
10-53270-221 ELECTRICITY	2,343.46	2,343.46	5,000.00	2,656.54
10-53270-350 BUILDING MAINTENANC	7,256.96	7,256.96	10,000.00	2,743.04
	13,500.74	13,500.74	20,500.00	6,999.26

TOWN OF DELAFIELD
General Fund - Statement of Expenditures
August 31, 2021

24	<u>Current Month</u>	<u>Year to Date</u>	<u>Annual Budget</u>	<u>Variance</u>
OPERATIONS				
10-53310-120 WAGES: FULLTIME	180,975.86	180,975.86	299,303.00	118,327.14
10-53310-125 WAGES: PARTTIME	9,194.43	9,194.43	10,175.00	980.57
10-53310-128 OVERTIME	4,274.43	4,274.43	10,175.00	5,900.57
10-53310-130 PERSONAL INSURANCE	25,139.01	25,139.01	46,041.00	20,901.99
10-53310-131 SOCIAL SECURITY	16,184.26	16,184.26	26,972.00	10,787.74
10-53310-150 RETIREMENT BENEFIT	20,241.93	20,241.93	32,923.00	12,681.07
10-53310-200 DRUG TESTING & EDUC	336.00	336.00	300.00	(36.00)
10-53310-223 SANITATION	205.62	205.62	425.00	219.38
10-53310-322 TUITION	0.00	0.00	500.00	500.00
10-53310-341 UNIFORMS	49.99	49.99	1,500.00	1,450.01
10-53310-343 EQUIPMENT RENTAL	560.00	560.00	2,000.00	1,440.00
10-53310-344 EQUIPMENT REPAIRS	10,104.32	10,104.32	35,000.00	24,895.68
10-53310-345 VEHICLE EXPENSES	19,965.46	19,965.46	30,000.00	10,034.54
10-53310-370 ROAD REPAIRS	487,501.45	487,501.45	550,000.00	62,498.55
10-53310-371 STREET SWEEPING	0.00	0.00	1,500.00	1,500.00
10-53310-372 ROAD SIGNS & MARKIN	2,150.95	2,150.95	11,000.00	8,849.05
10-53310-373 SAND, SALT & CHLORID	135,064.30	135,064.30	135,000.00	(64.30)
10-53310-374 CULVERTS & GRAVEL	1,625.56	1,625.56	5,000.00	3,374.44
10-53310-390 OTHER SUPPLIES & EXP	2,912.63	2,912.63	7,000.00	4,087.37
10-53420-221 ELECTRICITY	7,481.00	7,481.00	12,500.00	5,019.00
	<hr/>	<hr/>	<hr/>	<hr/>
	923,967.20	923,967.20	1,217,314.00	293,346.80
	<hr/>	<hr/>	<hr/>	<hr/>
TOTAL HIGHWAY & TRA	937,467.94	937,467.94	1,237,814.00	300,346.06
SEWER SERVICE				
10-56900-250 STORMWATER FEES DN	0.00	0.00	4,000.00	4,000.00
	<hr/>	<hr/>	<hr/>	<hr/>
	0.00	0.00	4,000.00	4,000.00
REFUSE COLLECTION				
10-53620-291 REFUSE COLLECTION	334,663.25	334,663.25	673,400.00	338,736.75
	<hr/>	<hr/>	<hr/>	<hr/>
	334,663.25	334,663.25	673,400.00	338,736.75
HEALTH & HUMAN SERVICES				
RECYCLING & WEED CONTROL				
10-53690-391 HAZARDOUS WASTE	1,502.60	1,502.60	1,000.00	(502.60)
	<hr/>	<hr/>	<hr/>	<hr/>
	1,502.60	1,502.60	1,000.00	(502.60)
ANIMAL CONTROL				
10-54100-291 HAWS	0.00	0.00	2,346.00	2,346.00
	<hr/>	<hr/>	<hr/>	<hr/>
	0.00	0.00	2,346.00	2,346.00
INSECT ERADICATION				
	<hr/>	<hr/>	<hr/>	<hr/>
	0.00	0.00	0.00	0.00
	<hr/>	<hr/>	<hr/>	<hr/>
TOTAL HEALTH & HUM	1,502.60	1,502.60	3,346.00	1,843.40

TOWN OF DELAFIELD
General Fund - Statement of Expenditures
August 31, 2021

<u>24</u>	<u>Current Month</u>	<u>Year to Date</u>	<u>Annual Budget</u>	<u>Variance</u>
PARKS & RECREATION				
PARKS				
10-55200-120 WAGES: FULL TIME	2,160.00	2,160.00	35,360.00	33,200.00
10-55200-125 WAGES: PARTTIME	1,035.00	1,035.00	0.00	(1,035.00)
10-55200-131 SOCIAL SECURITY	165.24	165.24	3,003.00	2,837.76
10-55200-150 RETIREMENT BENEFIT	0.00	0.00	3,890.00	3,890.00
10-55200-221 PARK ELECTRICAL SERV	120.95	120.95	200.00	79.05
10-55200-223 SANITATION	2,356.00	2,356.00	4,500.00	2,144.00
10-55200-345 VEHICLE EXPENSES	0.00	0.00	2,000.00	2,000.00
10-55200-355 GROUNDS MAINTENANC	2,459.23	2,459.23	5,500.00	3,040.77
10-55200-356 BASEBALL FIELDS	65.00	65.00	1,500.00	1,435.00
10-55200-390 OTHER SUPPLIES & EXP	0.00	0.00	900.00	900.00
	<u>8,361.42</u>	<u>8,361.42</u>	<u>56,853.00</u>	<u>48,491.58</u>
RECREATION				
10-55300-119 RECREATION DIRECTOR	8,938.60	8,938.60	13,671.00	4,732.40
10-55300-131 SOCIAL SECURITY	683.74	683.74	1,046.00	362.26
10-55300-222 TELEPHONE	315.68	315.68	650.00	334.32
10-55300-294 COUNTY LEAGUE FEES	4,025.00	4,025.00	3,000.00	(1,025.00)
10-55300-330 MILEAGE REIMBURSEM	0.00	0.00	300.00	300.00
10-55300-341 UNIFORMS	7,746.59	7,746.59	6,500.00	(1,246.59)
10-55300-346 BALL EQUIPMENT	1,535.04	1,535.04	1,000.00	(535.04)
10-55300-347 FIELD EQUIPMENT	724.72	724.72	900.00	175.28
10-55300-390 OTHER SUPPLIES & EXP	26.97	26.97	150.00	123.03
10-55300-395 LITTLE LEAGUE BREWE	0.00	0.00	3,000.00	3,000.00
10-55300-396 PICTURE NIGHT EXPENS	650.00	650.00	600.00	(50.00)
10-55300-397 SUMMER YOUTH PROGR	757.00	757.00	500.00	(257.00)
	<u>25,403.34</u>	<u>25,403.34</u>	<u>31,317.00</u>	<u>5,913.66</u>
TOTAL PARKS & RECRE	<u>33,764.76</u>	<u>33,764.76</u>	<u>88,170.00</u>	<u>54,405.24</u>
CONSERVATION & DEVELOPMENT				
ENGINEERING				
10-56300-215 ENGINEERING - REIMBU	3,369.25	3,369.25	20,000.00	16,630.75
10-56300-216 ROAD IMPROVEMENT P	25,409.50	25,409.50	36,000.00	10,590.50
10-56300-218 PLAN COMMISSION	7,810.75	7,810.75	14,300.00	6,489.25
10-56300-253 SPECIAL PROJECTS-NR21	2,031.25	2,031.25	10,000.00	7,968.75
10-56300-298 ENGINEER-BLDG GRADE	360.00	360.00	1,200.00	840.00
10-56300-299 CONTRACTED SERVICES	36,688.00	36,688.00	65,000.00	28,312.00
10-56300-300 ZONING CODE/UPDATE	0.00	0.00	2,000.00	2,000.00
10-56300-301 CODE ENFORCEMENT	0.00	0.00	500.00	500.00
	<u>75,668.75</u>	<u>75,668.75</u>	<u>149,000.00</u>	<u>73,331.25</u>
PLANNING COMMISSION				
10-56300-131 SOCIAL SECURITY	49.07	49.07	115.00	65.93
10-56300-141 MEETING FEES	641.04	641.04	1,500.00	858.96
10-56300-330 MILEAGE REIMBURSEM	1,675.46	1,675.46	2,500.00	824.54
10-56300-331 TOWN GIS	1,797.00	1,797.00	2,000.00	203.00
10-56300-332 MAP MODERNIZATION	500.00	500.00	0.00	(500.00)
10-56300-390 OTHER SUPPLIES & EXP	108.00	108.00	200.00	92.00
	<u>4,770.57</u>	<u>4,770.57</u>	<u>6,315.00</u>	<u>1,544.43</u>

TOWN OF DELAFIELD
General Fund - Statement of Expenditures
August 31, 2021

<u>24</u>	<u>Current Month</u>	<u>Year to Date</u>	<u>Annual Budget</u>	<u>Variance</u>
ZONING BOARD OF APPEALS				
10-56400-131 SOCIAL SECURITY	0.00	0.00	15.00	15.00
10-56400-141 MEETING FEES	157.71	157.71	200.00	42.29
10-56400-313 LEGAL NOTICES	126.20	126.20	50.00	(76.20)
	<u>283.91</u>	<u>283.91</u>	<u>265.00</u>	<u>(18.91)</u>
TOTAL CONSERVATION	80,723.23	80,723.23	155,580.00	74,856.77
CAPITAL OUTLAYS				
10-53310-810 HWY OPER'S-CAPITAL E	192,687.53	192,687.53	236,000.00	43,312.47
	<u>192,687.53</u>	<u>192,687.53</u>	<u>236,000.00</u>	<u>43,312.47</u>
TOTAL EXPENSES	<u>2,700,734.11</u>	<u>2,700,734.11</u>	<u>3,791,190.00</u>	<u>1,090,455.89</u>

**APPENDIX B
SUMMARY OF MUNICIPAL SPECIFICATIONS**

Municipal Summary of Current Services											
	<u>Units Served Refuse and Recycling</u>		<u>Government Facilities</u> (res = residential container)			<u>Appliance Collection</u>	<u>Bulky Items</u>	<u>Yard Waste</u>	<u>Average Tons</u>	<u>Average Tons</u>	<u>Average Tons</u>
Municipalities	Single Family - 4 Unit	Multi- Family	Sites	Size & Quantity Refuse	Size & Quantity Recycle	Curbside Frequency	Curbside Frequency	Curbside Drop-off Frequency	Solid Waste	2018-2020 Recycling	2018-2020 Yard Waste
Cities											
Oconomowoc	5,977		14	6-6yd; 4- 2yd; 1-1yd; 3-8yd; 1- 13yd	14-2yd; 1- 0.5yd	On call- fee paid by resident	weekly - curbside	weekly; seasonal, 20 weeks; curbside	4,900	1,761	1,022
Towns											
Delafield	3,160		2	2-3yd	1-2yd	weekly - on call	Weekly - curbside	4x/year; curbside	2,757	1,099	100
Merton	3,283		1	1-2yd	1-2yd	weekly - on call	Weekly - curbside, on call	Drop-off - weekly	2,170	949	0
Oconomowoc	3,546		1	1-4yd	1-2yd				2,663	976	0
Waukesha	3,225								2,836	876	889
Villages											
Dousman	673	10	2			weekly - on call	Weekly - curbside	4x/year curbside	586	184	29
Hartland	2,627		8	6-4yd; 2- 2yd; 8-res	4-res				2,353	772	0
Merton	1,107		4	1-2yd; 1- 4yd; 1-res	3-res; 1-2yd				795	307	79
Summit	1,981		2	2-2yd	2-2yd			9x/year; seasonal	1,600	577	93
									20,660	7,501	2,112

** All service information is estimated and subject to change. Blank spaces indicate that information was not available. Each Municipality reserves the right to negotiate for these services regardless of information provided in this summary.*

Municipal Service Specifications	
Municipalities	
Cities	
Brookfield	254 units within 4 multi-family complexes that use carts; 85 units within 4 multi-family complexes have dumpsters; 14,148 total units
Oconomowoc	
Waukesha	
Towns	
Delafield	
Merton	
Oconomowoc	Pricing for both on Bulky Items
Waukesha	
Villages	
Dousman	
Hartland	Weekly collection on not more than two days per week; 6:30am - 5 PM collection allowed; collection areas divided by railroad tracks: north side on Tuesdays, south side on Wednesdays
Merton	
Summit	UTD preferred for recycling and refuse; 9 yard waste pick-ups during the summer months, curbside



TRANSFORMING COMMUNITY DEVELOPMENT

Quarterly Business Review Delafield, WI

August 12, 2021

Measuring Success - Key Performance Indicators

KPI	Expectation	Performance			
		Overall for Quarter	Month 1	Month 2	Month 3
Plan Review Time Residential	5 days	5 days	5 days	5 days	5 days
Inspection Time	24 Hours	24 Hours	SLA's Met	SLA's Met	SLA's Met
One Stop Permits	Issued daily for certain types	Done Everyday			

Comments:

- Inspections 177 For 2nd Quarter 2021
- SLA's were consistently met or exceeded

Residential Valuation

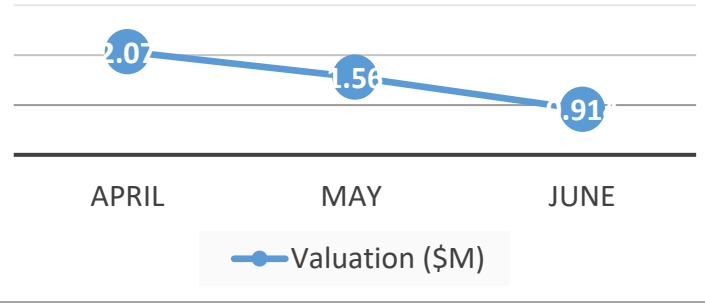

Commercial Valuation

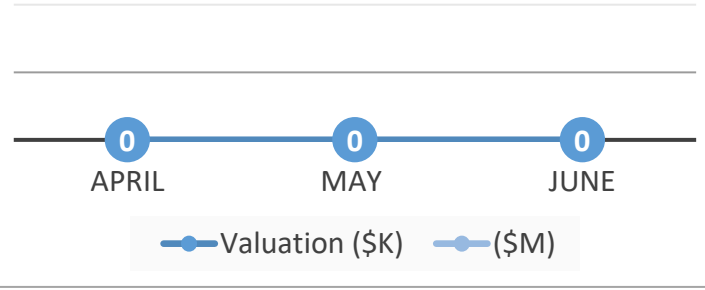

RESIDENTIAL

Review Permits - 177
 Inspections – 536
 78% passed

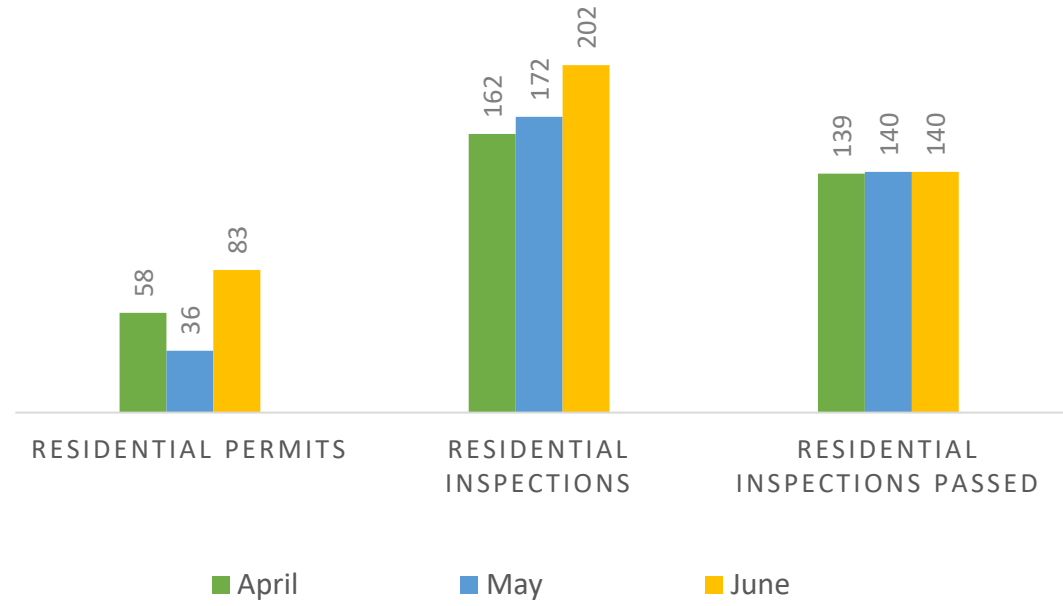

COMMERCIAL

Permits -5
 Inspections – 4
 100% passed

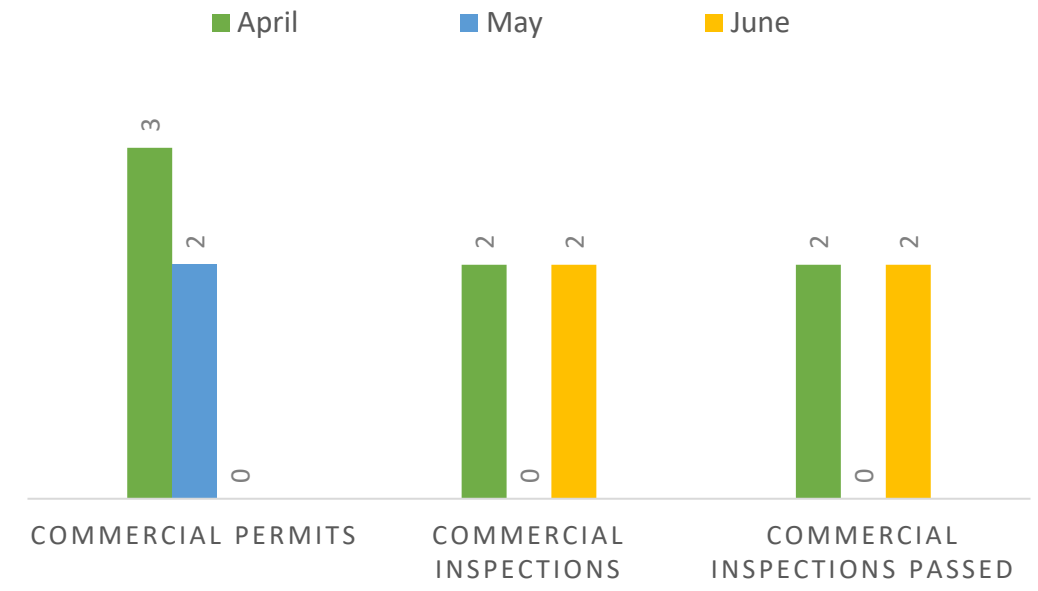

Residential Detail April – June

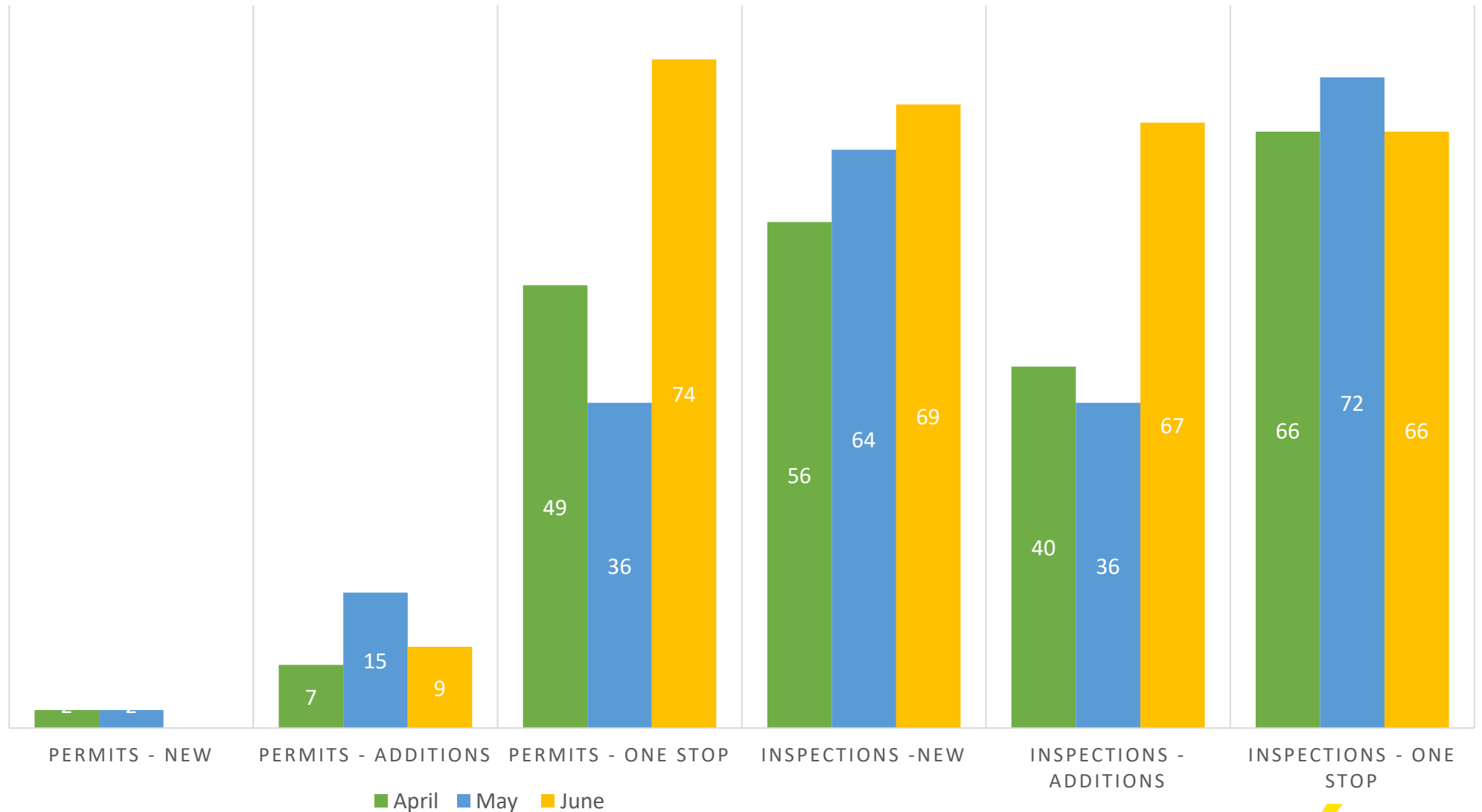

Commercial Detail April – June

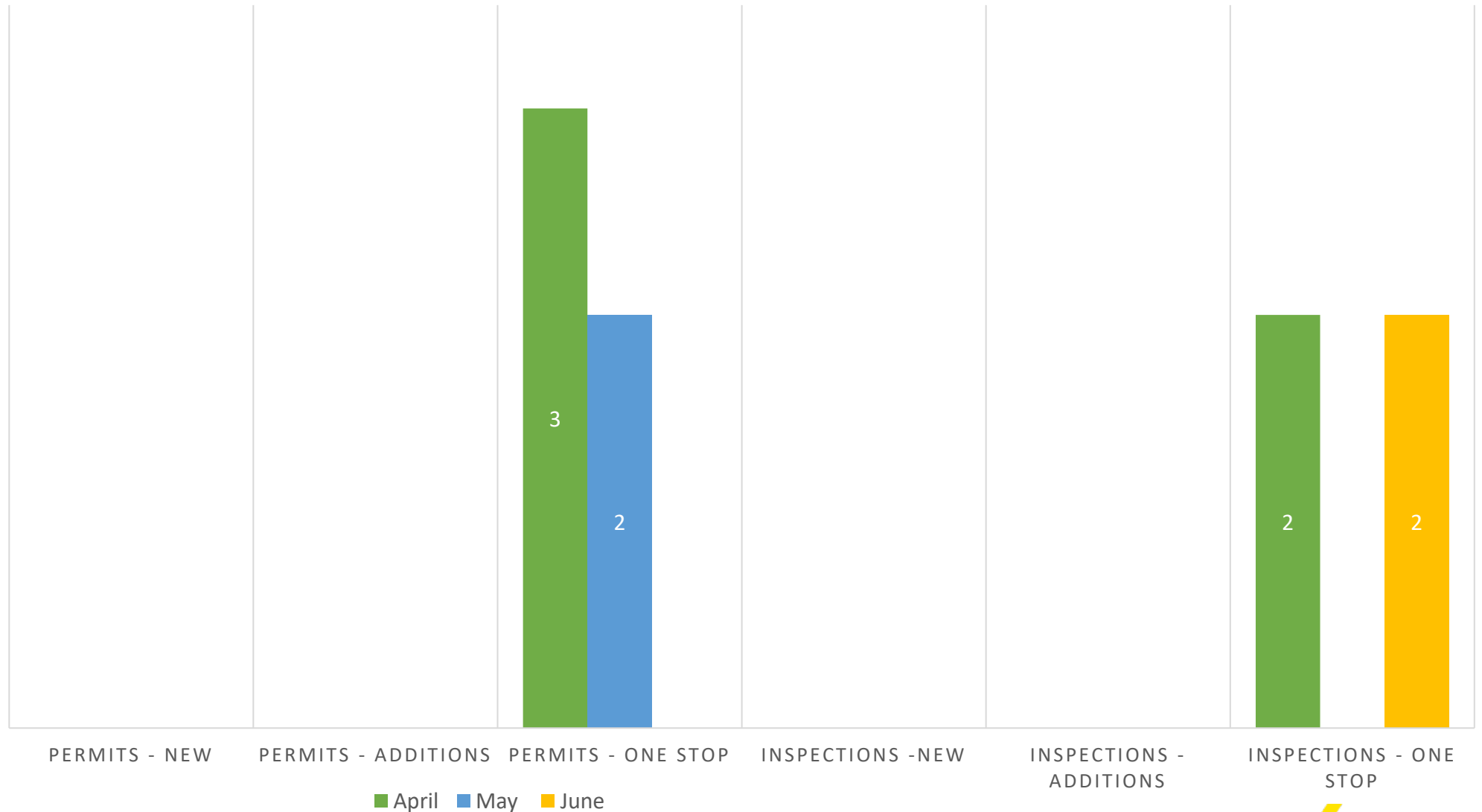

■ April ■ May ■ June



8.01 HIGHWAY COMMISSION.

A Town Highway Commission is hereby established consisting of the Town Chairman and Town Supervisors. The Town Highway Commission shall be charged with the care and supervision of all highways and roadways in the Town pursuant to Ch. 81, Wis. Stats.

(1) The Town Highway Commission shall supervise the hire or discharge of personnel such as technical assistants, road maintenance crews, emergency help and shall contract for, as deemed necessary, materials, work and equipment to construct, repair and maintain the Town Highways with competitive bids being taken, as deemed necessary, on gravel, salt and sand, paving materials, equipment rentals, repair work, new construction or reconstruction on Town roads and mill tax roads new construction or reconstruction.

(2) Cause to have done such other things as are normally necessary to construct, build, maintain, improve, delete, abandon, obtain, condemn, purchase roads and rights-of-way and portions thereof.

(3) Post parking restrictions, either temporary or permanent, at any place where vehicular parking hinders the maintenance of Town highways or vehicular traffic thereon, prevents the proper removal of snow from the Town highways, or endangers the public safety or welfare.

(4) Proclaim the state of snow or other emergency through the press, radio or other public means of communication, and designate and authorize law enforcement officers and other personnel to inform the citizenry of the existence of the emergency. Cause the removal of any vehicle which may interfere with the operation of any snow removal equipment or any emergency vehicle to the owner or operator thereof. Such removal may be made either by Town personnel or by any garage man, service man, person, firm, or corporation designated by the Town Board or authorized agent thereof. Prosecute according to the provisions of this section any person who shall permit any vehicle to park or stop upon any uncleared Town or Town maintained highway, either during a driving snowstorm, immediately thereafter, or during a state of declared emergency in such a manner as to interfere with snow removal or other emergency equipment, unless with reasonable diligence he could not avoid it.

(5) Provide for the public safety on Town highways by posting stop signs, school and road hazard warning signs, etc., where, in its opinion, they are necessary for public good, removing obstruction of view at dangerous intersections or points in road, enforcing corner setbacks, fence and obstruction heights, line of vision, etc. per the Zoning Code, and cause the legal speed limits established by Town and County ordinances and State Statutes to be enforced on all roads in the Town.

(6) Cause public utilities to submit maps showing the location of any underground facilities within the right-of-way of any Town highways and Town maintained highways.

(7) Appoint a Superintendent of Highways who shall supervise the construction and maintenance of all highways and roadways in the Town required to be maintained by the Town, and keep them passable at all times, and perform such other services in connection with the highways as the Town Board requires, and keep a full account of all his receipts and disbursements. He may make such arrangement for the prosecution of his work as he deems necessary and appoint such foreman as the highway work requires. When any highway under his charge becomes impassable, he shall put the same in passable condition as soon as practicable. He shall make a complete and full report of all funds received and disbursed by him whenever requested so to do by the Town Board, and shall also make a complete and full report at each annual Town meeting. The Superintendent, and in his absence, the Town Board, shall immediately upon notice of its existence fill or remove any depression, ditch, hump or embankment which impedes the use of any highway in the Town. The Superintendent shall specify the size and location of all drainage culverts along or under Town highways or on private lands, where necessary, and perform all services in connection with the Town highways as the Town Highway Commission may require.

8.02 DRIVEWAYS AND CULVERTS.

1

Formatted: Centered

(1) **CULVERTS TO BE INSTALLED.** (Am. #88-200) No driveway shall be constructed or maintained connecting with any street unless a suitable culvert is first installed across the roadside ditch at the street, where necessary. The culvert shall be set to the finished grade as established or at the grade established by the Town Highway Superintendent. Such culvert shall be constructed of corrugated metal pipe and shall have a cross section of not less than that of a 15" pipe. The length of the culvert shall be as required by the Town Highway Superintendent and shall be installed by the Highway Superintendent. All culverts shall be equipped with end guards made of concrete or steel and shall be so installed as to not be beyond street height. Any person who wishes to have a culvert installed on any Town road shall first make application therefor with the Town Highway Superintendent. The applicant shall deposit a fee equal to the estimated cost of installation. The culvert and end sections shall be provided by the applicant and installed by the Town Highway Superintendent. On any county or State highway, application shall be made to the Waukesha County Highway Department. ~~No concrete surfacing shall be installed over any culvert within the road right-of-way.~~

(2) **EXISTING DRIVEWAYS.** Where the public welfare requires a suitable culvert for an existing driveway, the Town Board shall notify, in writing, the property owner maintaining the driveway across any gutter in any street, that the Town will install a culvert at the expense of the abutting property. The property owner shall deposit a sum in an amount equal to the estimated cost of installing such culvert within 10 days from date of notice. If the deposit is not made, the cost of the installation will be charged to the abutting property and, if not paid to the Town Treasurer on or before November 1, shall be entered on the tax roll as a special tax against the property.

(3) **FINANCIAL GUARANTEES REQUIRED FOR LANDSCAPING OF ROADSIDE DITCHES.** (rep. & rec. 17-626)

- (a) Guarantee Specifications. All applications for a private driveway culvert installation shall include a cash deposit, letter of credit or bond in the amount set forth from time to time by resolution of the Town Board to insure proper completion of the landscaping restoration of the roadside ditch, in addition to the cost for such installation. This cash deposit, letter of credit or bond shall be for the roadside ditch adjacent to the culvert installation, shall be in a form approved by the Town Attorney, and shall be specifically applicable to the property for which a private driveway or culvert installation application has been made and shall not cover any other property. The cash deposit, letter of credit or bond will be held by the Town until the roadside ditch landscape restoration has been completed and approved by the Town Highway Superintendent~~Building Inspection Department~~ or authorized designee.
- (b) Inspection for Return of Guarantee. The property owner may request return of the financial guarantee required in subsection (a) at any time upon completion of the culvert installation and landscaping restoration. Upon such request, the Town Highway Superintendent~~Building Inspector~~ or authorized designee shall make an inspection of the installation and restoration and if properly restored and landscaped, shall authorize return of the financial guarantee. If no request is made for an inspection within a year of the installation of the culvert, the Town shall make an inspection of the culvert and roadside ditch adjacent thereto, and if such installation is in proper condition and the landscaping and restoration of the ditch and culvert are properly completed as determined by the Town Highway Superintendent~~Building Inspector~~ or authorized designee, then the financial guarantee shall be returned to the owner.
- (c) Unsatisfactory Landscape/Repair. If any work needs to be done on the landscaping or any restoration of the ditch or repair of any damage due to construction or erosion in the opinion of the Town Highway Superintendent~~Building Inspector~~, this work shall be done by the Town and the property owner shall be billed therefore by the Town. If such bill is not paid within 30 days, the amount thereof shall be charged to the financial guarantee provided by the owner and the balance thereof shall be released by the Town to the property owner as herein provided.

Formatted: Centered

(4) SURFACING OF PRIVATE DRIVEWAYS AND TOWN RIGHT-OF-WAYS. (rep. & rec. 2002-02-004)

- (a) Concrete Surfacing of Private Driveways. No concrete surfacing shall be installed on a private driveway closer than 3' from the hard surface on the road right-of-way. If for any reason any portion of the driveway in the town right-of-way would need replacing, the town shall not be responsible for the cost of the repair or the replacement. No concrete surface driveway shall be installed on any private driveway until a permit has been obtained from the Building Inspector and shall indicate the width and length of such driveway to be installed. The Building Inspector shall advise all owners of property of the requirement for such permit at the time when the application for a building permit for the construction of any residence or other building on the premises is applied for. The amount of said permit fee shall be set by the Town Board from time to time by resolution.
- (b) Asphalt or Concrete Surfacing of Private Driveways within and Town Right-of-Ways. If for any reason any portion of a driveway that extends into the Town right-of-way needs to be constructed, repaired, replaced or resurfaced with asphalt or concrete to comply with existing Town street grade, the Town shall not be responsible for the cost of the construction, repair, replacement or resurfacing. Concrete driveways shall not extend any closer than three (3) feet to the edge of the paved road. No concrete asphalt construction, repair, replacement or resurfacing shall be installed until an application has been submitted and approved to by the Town Highway Superintendent. After an application has been approved by the Town Highway Superintendent, the property owner shall may contract with a private contractor for the asphalt construction, repair, replacement or resurfacing. ~~or the property owner may elect to use the asphaltting service of the Town. If the property owner elects to use the asphaltting service of the Town, the property owner shall, prior to any construction, deposit a fee equal to the estimated time, materials and administrative costs of the asphalt construction, repair, replacement or resurfacing. After the asphalt construction, repair, replacement or resurfacing has been completed by the Town, the property owner shall be billed by the Town. Any amount owed by the property owner which is over and above the amount of the property owner's deposit shall be paid within 30 days. If the amount is not paid to the Town Treasurer on or before November 1, the Town shall have the amount owed entered on the tax roll as a special tax against the property. The Town shall pay to the property owner any amount which represents the difference between the deposit of the property owner and the actual costs of the asphalt construction, repair, replacement or resurfacing which is lower than the property owner's deposit.~~

(5) STREET GRADE. (Cr. #88-200) Every building hereafter erected, structurally altered or relocated shall be located on an improved street at a grade approved by the Building Inspector as being in satisfactory relationship with the established grades, if any, and, if not, with existing street grade, with particular consideration for proper drainage and safe vehicular access. Safe vehicular access is defined as a paved driveway of sufficient width and adequate horizontal alignment to accommodate emergency vehicles and a slope not to exceed 12% at any such point. Driveways shall be graded and graveled before construction commences. Cases in question may be referred to the Plan Commission by the Building Inspector.

(6) FINANCIAL GUARANTEES REQUIRED FOR REPAIR OF CURB AND GUTTERS (rep & rec. 17-626)

- (a) Whenever a building permit is issued in an area where curb and gutter sections exist, the financial guarantee herein provided in subsection (3) above shall be required. This guarantee shall insure any necessary repairs to the curb and gutter section which may be damaged as a result of the construction activities authorized by the building permit.
- (b) The Highway Superintendent shall make an inspection of the curb and gutter adjacent to the premises after an occupancy permit has been granted by the Building Inspector. Return of the financial guarantee shall be as subsection (c) below.

- (c) If there is any damage to the curb and gutter sections as a result of the authorized construction activities, the damage shall be repaired by the Town and the cost thereof billed to the owner. If such bill is not paid within 30 days, the amount thereof shall be charged to the financial guarantee provided by the owner and the balance thereof shall be released by the Town to the property owner.

8.03 EXCAVATION

(1) **PERMITS REQUIRED.** No person shall make or cause to be made any excavation in or under any street, alley, public grounds or sidewalk in the Town without first obtaining from the Town a written permit. Such permit shall be issued only upon a written application signed by the person desiring to make the excavation. The application shall describe the place where the excavation is proposed to be made with such certainty that it may be readily located, and shall specify the purpose for which the excavation is to be made and when it is proposed to begin. Applicants shall pay a non-refundable application fee in an amount which shall be set forth from time to time by resolution of the Town Board.

(2) **FINANCIAL REQUIREMENTS.**

(a) **Performance Bond.** A performance bond binding the applicant, as principal, and a separate surety licensed to do business in this State, as surety, to the Town in an amount as set forth from time to time by resolution of the Town Board, the condition voiding the bond being that the applicant will perform and fully complete in a ~~workmanlike~~ manner approved by the Town Highway Superintendent, all work for which any highway and street opening permit is issued during the term of the bond in accordance with the provisions of this chapter and all other laws of any sort, and within the time prescribed by the Town Highway Superintendent. In addition, such bond shall provide that the applicant will backfill, maintain and restore the surface of any Town highway, Town maintained highway, street,

(b) **Indemnity Bond or Certificate of Insurance.**

1. **Bond.** An indemnity bond binding the applicant, as principal, and a corporate surety licensed to do business in this State, as surety, to the Town in the penal sum of \$10,000, the condition voiding the bond being that the applicant shall indemnify and save harmless the Town, its officers, agent and employees and shall defend the same from and against any and all liability claims, loss, damages, interest, actions, suits, judgments, costs, expenses, attorney's fees and the like, to whomsoever owned and by whomsoever brought or obtained, which may in any manner result from or arise in the course of or out of the performance of any work for which any highway and street opening permit is issued to the applicant during the term of the bond or of any work incidental thereto; the bond shall provide that the penal sum of \$10,000 does not and shall in no manner be construed to limit the legal liability of the applicant (who is principal thereon) to indemnify or otherwise reimburse the Town for any loss, damage or expense it may incur through the defaults, acts or omissions of the applicant in the performance of any work for which a highway and street opening permit is issued to the applicant.
2. **Insurance.** In lieu of the indemnity bond, the applicant may deposit with the Town Board a certificate of insurance showing that the applicant is maintaining in force a bodily injury liability insurance policy or policies subject to limits of not less than \$10,000 each person and \$20,000 each accident and property damage insurance subject to a limit of not less than \$10,000 each accident, against all risks of damage or injury (including death) to property or persons which may in any manner result from or arise in the course of or out of the performance of any work for which any highway and street opening permit is or may be

Formatted: Centered

issued to the applicant, or of any work incidental thereto by reason of the defaults, acts or omissions of the applicant, his officers, employees, agents, workmen or independent contractors; such insurance policy or policies shall be issued by companies authorized to do business under the laws of this State and shall contain endorsements or riders insuring the applicant's liability to indemnify or otherwise reimburse the Town for any loss, damage or expense it may incur through the default, acts or omissions of the applicant in the performance of any work for which a permit is issued to the applicant; the certificate of such insurance must show the expiration date of the insurance policy and must provide that the insurance policy cannot be changed or canceled except upon 10 days' notice to the Town. If such insurance policy expires or is canceled within one year of the date of issuance of any highway and street opening permit, similar insurance must be provided without any gap in coverage of the indemnity bond previously described must be similarly provided.

- 3. Form. The bonds shall be in the form designated or approved by the Town Board, and the Town Board shall also approve the sureties and any certificate of insurance. Bonds may be furnished to cover each individual permit applicant, or an applicant may furnish bonds covering work under all permits granted within a stated period, and may periodically renew the same. The obligation of such bonds shall remain in full force and effect after date of expiration as to any work for which a permit was granted prior to expiration.

(3) SPECIFICATIONS FOR HIGHWAY AND STREET OPENINGS.

- (a) No openings in Town highways, Town maintained highways, streets, alleys, other public ways or public lands will be permitted when the ground is frozen except when necessary in the opinion of the Town Board. In making such an opening all materials excavated from existing or proposed pavements or driveways or within 5' of the edges thereof, shall be removed from the site and disposed of by the applicant in a manner approved by the Town Highway Superintendent.
- (b) All openings made in accordance with permission given pursuant hereto shall be enclosed with sufficient barriers, and lamps shall be maintained upon the same at night. All other necessary precautions shall be taken to guard the public against accidents from the beginning to the completion of the work. Underground facilities may be laid only on condition that the applicant is bonded as hereinbefore mentioned from all damages that may result from his neglect of necessary precaution against all accidents to persons or property of others.
- (c) In opening a trench in any Town highway, Town maintained highway, street, alley, other public way or public lands, the excavated and work areas must be restored to precisely the same condition and relation to the remainder as they were before. All rubbish, boulders and other undesirable materials not used in backfilling must be removed at once and the excavated areas shall be left in perfect repair. The person to whom a permit is issued hereunder shall be responsible for one year after approval of the filling and surfacing for any settling, and shall be liable for all damages resulting from failure to repair such settling.
- (d) When any excavation is made in an existing or proposed pavement or driveway, or within 5' of the edge thereof, all excavated material must be removed and the excavation backfilled with slurry to 4-inches below the surface of the pavement in a manner approved by the Town Highway Superintendent. The top 4-inches shall be asphalt pavement conforming to specifications in this Chapter, to within 5" of the surface within 1-1/2" maximum crushed gravel containing at least 60% crushed stone. Gradation of the gravel backfill shall conform to the applicable standards of the State Department of Transportation. Any C concrete pavement shall be replaced in kind. Concrete shall meet the following specifications:

Minimum cement content - sacks per cubic yard	6.0
Compressive strength after 28 days cured	3,500 psi
Maximum amount of water per sack of cement	6.0 gallons

Formatted: Centered

Size of coarse aggregate required	No. 1 plus No. 2
Slump	1 Inch - 3 Inches
Air Content	4.5% - 7.5%
Admixtures (including flyash) shall NOT be allowed.	

Any tunnels shall be backfilled with 4 1/2 bag mix concrete in a manner approved by the Town Highway Superintendent and Town Engineer. ~~Restoration in streets surfaced with bituminous concrete pavement shall conform to specifications on file in the office of the Town Clerk.~~

Formatted: Indent: First line: 0"

- (e) No work shall be performed and no opening or excavation shall be made within the limits of any Town maintained highway, street, alley, other public way or public lands without prior notification in writing to the Town Highway Commission, to be given at least 48 hrs. before commencement of the work.
- (f) Traffic shall not be shut off from travel over the highways without express authority from the town Highway Commission.
- (g) All pipelines shall be installed and laid so as not to interfere with the use of the highways by the public nor the use of the adjoining land by the owner thereof, and no trees or bushes shall be cut, trimmed or the branches thereof cut or broken in the construction or maintenance of any line without the consent of the owner of the trees or bushes.
- (h) If any utility services installed by the applicant shall interfere with the maintenance or construction, within the right of ways of any streets or public way, the utility services shall be realigned at no expense to the Town.

8.04 HEAVY OR INJURIOUS VEHICLES RESTRICTED.

No machine having lugged wheels or metal tracks or weighing more than 3 tons shall be driven or operated upon or along any street, alley or public place in the Town unless a permit therefore shall first be secured from the Town Highway Superintendent, which permit shall specify the route to be taken by such machine and it shall be unlawful to deviate from such route. The Town Highway Superintendent may require the removal from any machine of any flanges, cleats, or other removable parts which could damage the streets, and also require, whenever in his judgment it is necessary that planks, plywood, plates or other sufficient protection for the streets be provided by the person driving or operating any such machine and be placed by such person on the street, and the machine shall be run upon such planks, plywood, plates or other protection when such requirement is made. ~~Farm vehicles, such as tractors, combine harvesters, hay wagons, etc. shall be exempt from these requirements.~~

8.05 TEMPORARY WEIGHT RESTRICTIONS.

(1) GENERAL. The Town may limit the use of any Town road, bridge or culvert at any time, to the use of motor vehicles having a gross vehicular weight, regardless of the number of axles, of not more than 6 tons. Such restrictions may be imposed by the Town Highway Superintendent when in his judgment the use of any Town road, bridge or culvert would be damaged or destroyed by use for motor vehicles having a gross weight in excess of the limitation herein provided because of weakness of the roadbed, bridge or culvert due to deterioration or climate conditions or other special or temporary conditions.

(2) TEMPORARY LIMITS. Such temporary weight limitation shall be imposed by erecting signs on or along the Town road on which it is desired to impose the limitation sufficient to give reasonable notice that a temporary weight limitation is in effect and the nature of that limitation. Any temporary weight limitation as provided herein with reference to any bridge or culvert shall be imposed by erecting similar signs within 100' of each end of the bridge or culvert to which the weight limitation applies. All such temporary weight limitation signs shall comply with the rules of the State Department of Transportation.

Formatted: Centered

(3) SPECIAL PERMIT. The Town may grant a special permit to the owner or operator of any motor vehicle having a gross weight in excess of the weight limitation herein imposed to operate the motor vehicle on any Town road while the weight limitation is in effect, if in his judgment an emergency condition exists which requires the use of such motor vehicle, and if the use of such motor vehicle would not damage the Town road on account of weather and street conditions at the time the permit is applied for. If such permit is issued, it shall be limited to the vehicle or vehicles described thereon and such permit shall name the street or streets upon which the vehicle or vehicles may travel, the gross vehicular weight allowed and the time that such permit shall be in effect. Applications for such permits shall be made to the [Town](#) Highway Superintendent.

8.06 DAMAGING STREETS PROHIBITED.

No person shall injure, tear up or remove any pavement, sidewalk or crosswalk or any part thereof, or dig any holes, ditches or drains in or remove any sod, stone, earth, sand or gravel from any street, lane, alley or public ground within the Town without obtaining a permit from the Town.

8.07 BARRICADES, INTERFERENCE WITH PROHIBITED.

No person shall remove an authorized barricade from any street or injure the same or drive upon any street which has been properly barricaded.

8.08 PLACING INJURIOUS SUBSTANCE ON STREET PROHIBITED.

No person shall place or cause to be placed upon a street, alley or sidewalk any foreign substance which may be injurious to any vehicle or part thereof.

8.09 LITTERING PROHIBITED.

No person shall throw or deposit any debris or waste material on any street, alley, sidewalk or other public or private property.

8.10 DEBRIS FROM VEHICLES PROHIBITED.

No operator of any vehicle shall permit to be thrown or deposited therefrom any type of debris or waste material. This section shall prohibit the deposit, upon the streets, alleys or sidewalks, of mud, gravel or dirt from the wheels or tires of a vehicle.

8.11 SPILLING DEBRIS FROM VEHICLES PROHIBITED.

No operator of any vehicle transporting waste or foreign matter shall permit such to be spilled on or along any street, alley or sidewalk.

8.12 VEHICULAR TRAFFIC OVER DRAINAGE DITCHES AND STREET CURBS.

(1) DEFINITION. "Motor vehicle" means every device in, upon or by which any person or property is or may be transported or drawn upon a public street including, but not limited to, passenger motor vehicles, motor trucks, tractors, earth moving equipment and any other type of motor drive vehicles.

(2) PROHIBITED. No person shall operate any motor vehicle over, along or into any drainage ditch adjacent to any public street nor over a street curb except over an established driveway, except that a contractor may drive through a drainage ditch if this is necessary for the repair of an existing well or private sewage disposal system, or for the installation of sanitary sewer or water laterals. In such event the contractor having the plumbing permit for such work shall be responsible for the repair of the ditch and road surface. This repair must be made to the satisfaction of the Superintendent within 30 days after the work is completed. Until such satisfactory repairs are made, the Plumbing Inspector shall not issue

Formatted: Centered

any further plumbing permit to the contractor involved.

8.125 UNPAVED HIGHWAY RIGHT-OF-WAY AREAS; ENCROACHMENTS PROHIBITED. (Cr. #89-224)

- (1) Pursuant to §§86.03 and 86.04, Wis. Stats., from and after the enactment hereof, no person shall plant trees, shrubs or stone formations or unsafe mail boxes within the dedicated highway right-of-way areas adjacent to the paved portion of such highway. This section shall not apply to typical flared end of culverts.
- (2) The Town Board may grant special exceptions to this section for good cause shown.

8.13 STANDARDS FOR THE CONSTRUCTION OF TOWN HIGHWAYS.

- (1) ARRANGEMENTS. The provisions of Ch. 18 of this Code shall apply.
- (2) DESIGN STANDARDS. The provisions of Ch. 18 of this Code shall apply.
- (3) REQUIRED IMPROVEMENTS. The provisions of Ch. 18 of this Code shall apply, and other facilities deemed necessary to the Town Board, including storm sewers, sanitary sewers, curb and gutters, bridges, water systems, etc.
- (4) CONSTRUCTION STANDARDS. These construction standards and the previously listed design standards and required improvements shall apply to any party desiring acceptance by the Town of any road to be subsequently designated a Town highway and maintained by the Town. No road to be ultimately accepted as a Town highway and not shown on the Official Town Highway and Street Map shall be constructed without previous approval of the Town Board.
 - (a) The typical section for local residential Town roads is shown on Exhibits "A" and "B" and "C" at the end of this chapter. The typical section for all other roads shall be designated by the Town Engineer. (Am. #90-264)
 - (b) The Town Board shall require that profiles of roads to be constructed and accepted, be prepared by a Registered [Professional Engineer](#) or ~~Land Surveyor~~ in the State and be submitted to the Town Board for approval of the established grades on all of the proposed highways and drainage easements prior to preceding with any grading operations. ~~The Town Board shall determine the maximum and minimum slope in any cut to be made in connection with the construction of any Town highway, and the type and character and amount of fill necessary for the construction of any such highway, before any grading operations shall commence.~~
 - (c) Before commencing with any earth moving operations, the contractor shall [obtain an erosion control and storm water management permit from Waukesha County Parks and Land Use Department, Land Resources Division](#), ~~construct sedimentation basins to eliminate erosion to downstream areas~~. A drainage plan shall be submitted and shall consider the following: Temporary cover during grading operations; permanent grass and vegetative cover by use of stabilization materials, such as mulch, jute mat, excelsior, low growing plants, vines, and sod; construction of diversionary channel and terracing access slopes; and leaving critical areas in undisturbed condition. The drainage plan shall be approved by the Town before the developer may proceed with any grading operations.
 - (d) Topsoil, peat, unstable material, all vegetative cover, stones, stumps, roots, and other deleterious materials shall be removed below the subgrade of the roads and replaced with sound fill materials placed and compacted to the satisfaction of the Town [Highway Superintendent and Town Engineer](#). Any rock encountered shall be excavated to a point at least 20" below the finished grade of the roads. The contractor shall not proceed with the graveling operations until the

8

subgrade has been checked for proper grade, proof-rolled and approved by the Town Engineer.

(e) After the subgrade has been approved, the contractor shall place a minimum of 10" of 1 1/4-inch dense graded base course in accordance with Section 305 of the crushed aggregate on the road bed in 2 lifts. The lower lift shall be 5" thick gradation no. 1 and the top lift shall be 5" thick gradation no. 2, conforming to §304.2.6. Standard Specifications for Road and Bridge Construction, Division of Highways, State Department of Transportation (State Specifications), most recent edition. Acceptable base materials shall be crushed stone or crushed gravel. In areas that are wet or seasonably wet, a minimum 6" layer of no. 2 stone shall be placed below the 10" base course layer at the direction of the Town Board. For areas that fail the proof roll, the contractor shall excavate to an elevation at which the contractor has determined that he/she can pass the proof roll, install a filter fabric (Type SR, Chapter 645 State Specifications), and fill the excavation with 3-inch dense graded base course and compact. The Town Board may require that the aggregate be tested at the owner's expense by an approved testing laboratory before being placed on the road. If additional material is required, in the opinion of the Town Highway Superintendent or Town Engineer Board, to stabilize the road, the same shall be furnished and applied to the satisfaction of the Town Highway Superintendent or Town Engineer Board before acceptance, at no cost to the Town. (Am. #90-264) Shoulders, if required, shall be 3/4-inch crushed stone or crushed gravel.

(f) After the aggregate has been placed and approved by the Town, 4-inches of bituminous concrete shall be placed in two lifts. The lower (binder) lift shall be a 2 1/2 4-inches" lift of bituminous concrete 3 LT 58-28 S placement gradation no. 2 shall be installed in accordance with §4602 of the Standard Specifications. The Town may require that the asphalt course be cored to determine adequate thickness. The cost of these tests shall be paid by the developer. If the lower initial lift should be found to be less than 2 1/4 2-inches" in thickness, the average deficiency shall be determined by the Town Engineer and a proportionate increase be made in the final lift. The upper (surface) lift shall be 1 3/4-inches of bituminous concrete 5 LT 58-28 S, unless otherwise approved by the Town Highway Superintendent and Town Engineer. Other mix specifications may be used or required based on traffic analysis and site conditions, and shall be approved by the Town Highway Superintendent and Town Engineer. If the final thickness is found to be deficient, the deficiency shall be remedied by placing a lift over the entire roadway equal in thickness to such deficiency, but in no case less than 1-inch". (Am. #90-264)

(g) Curb and gutter that meets the requirements shown on Exhibit "D" shall be installed on the inside of all curvilinear roads and at all radii of intersections.

(h) Developer may install curb and gutter with storm sewer throughout the entirety of a subdivision, if approved by the Town Board, after recommendation from the Town Highway Superintendent and Town Engineer. Curb and gutter shall meet the requirements of Exhibit "D." Storm sewer shall meet the following standards:

Pipe: Reinforced Concrete Pipe

Catch Basins: File No. 29 (Green Book) with Neenah 3508 B Frame and Grate

Manholes: File Nos. 11 or 12 (Green Book)

Construction specifications shall be in accordance with the Standard Specifications for Sewer and Water Construction in Wisconsin, with Addendums (Green Book)

Formatted: Not Highlight

Formatted: Not Highlight

Formatted: Not Highlight

(g) When roadways intersect a collector street, County trunk highway, or State trunk highway, deceleration and acceleration lanes, flairs, tapers and/or increased radii may be required on one or both of the intersecting streets. The Town Engineer shall determine the location of these lanes, etc. These areas shall be graded, stoned graveled, paved and landscaped as specified herein.

(h) All culverts shall be corrugated metal pipes or reinforced concrete pipe with standard end sections. ~~When~~

Formatted: Centered

(H) Ditches and side slopes along roads and in easements shall be covered with a minimum of 4" of topsoil free of all stones, roots and other debris, graded, seeded and/or sodded, mulched, fertilized and maintained for a sufficient period to provide adequate grass cover prior to acceptance by the Town. Unless specifically altered by the Town Board, the following standards shall be followed:

Formatted: Centered

<u>SLOPE OF DITCH</u>	<u>MINIMUM RESTORATION STANDARD</u>
<u>Less than 1.25%</u>	<u>No ditch is allowed to be less than 1.25% slope</u>
<u>1.25% to 2.00%</u>	<u>Ditch bottom shall be seeded and staked with jute matting or similar material.</u>
<u>2.00% to 4.00%</u>	<u>Ditch bottom shall be sodded and staked with jute matting or similar material.</u>
<u>4.00% to 8.00%</u>	<u>Ditch bottom shall be sodded.</u>
<u>Over 8.00%</u>	<u>Ditch bottom shall be paved.</u>

Town Engineer and Town Highway Superintendent may allow alternative restoration standards based on individual site conditions.

Formatted: Font: Not Bold

Slopes

~~Less than 0.50%~~

~~0.50% to 2.00%~~

~~2.00% to 4.00%~~

~~4.00% to 8.00%~~

~~Over 8.00%~~

~~Ditch bottom shall be seeded and staked with jute matting or similar material.~~

~~Ditch bottom shall be sodded and staked with jute matting or similar material.~~

~~Ditch bottom shall be paved or lined with stone rubble.~~

~~Ditch bottom shall be paved.~~

~~Ditch bottom may be seeded.~~

8.14 OFFICIAL TOWN HIGHWAY AND STREET MAP.

To facilitate the carrying out of the provisions of this chapter, the Town Board may, in cooperation with the Town Plan Commission, have prepared and subsequently adopt an official Town Highway and Street Map. This map shall become a part of this chapter after adoption and publication by the Town Board and may include: location, width, weight restriction, if any, and the name of all Town, County, State, federal, mill tax roads, and Town owned rights-of-way.

8.15 ADOPTION, AMENDMENTS, AND EFFECTIVE DATE.

Amendments to this chapter shall take effect and be in full force after adoption by the Town Board following a public hearing. Notice of this public hearing shall be given by publication in the official newspaper at least 3 times preceding the hearing and giving not less than 10 nor more than 30 days notice prior to the hearing.

8.16 UNIFORM ADDRESS SYSTEM.

(1) ADOPTED. The uniform address system of the Town shall be based on and become a part of a

11

Formatted: Centered

uniform address system for Waukesha County, as recommended by the County Board on March 12, 1957. All provisions herein relating to the establishment of a uniform address system for the County are hereby approved, and such provisions are applicable to the Town as more specifically set forth in the following sections, are hereby adopted by the Town Board.

(2) ESTABLISHED. There is hereby established a uniform system of numbering properties fronting on all streets, highways and rights-of-way in the Town and all existing residences and places of business and all residences and places of business which are hereafter constructed shall be numbered in accordance with the provisions of this section.

(3) BASE LINES.

- (a) Base lines, as recommended for a uniform County address system, shall be used for determining the numbering in the Town. The east west line, as recommended, shall be used for numbering along all streets running north and south. This base line shall be a continuation of the east west base line used in Milwaukee County and shall be the north or top line of Sections 31 to 36 inclusive in the Towns of Brookfield, Pewaukee, Delafield and Summit. Its numerical designation shall be "1". A north south base line, as recommended, shall be used for numbering along all streets running in a westerly direction. This base line shall be the eastern boundary of Waukesha County and its numerical designation shall be "124".
- (b) Each property north of the east west base line and facing a street running in a northerly direction shall carry an address indicating its position west of the north south base line and its position north of the east west base line.
- (c) Each property south of the east west base line and facing a street running in a southerly direction shall carry an address indicating its position west of the north south base line and its position south of the east west base line.
- (d) Each property west of the north south base line and facing a street running in a westerly direction shall carry an address indicating its position either north or south of the east west base line and its position west of the north south base line.
- (e) Properties on diagonal or curvilinear streets shall be numbered the same as or similarly to, properties on northerly or southerly streets if the diagonal or curvilinear streets run more from the north to the south. The same shall hold for diagonal or curvilinear streets which run more from the east to the west in that properties on such streets shall be numbered the same as, or similarly to, properties on westerly streets.
- (f) Where the general direction of a diagonal or curvilinear street has a deviation of exactly 45 degrees, the direction of the street shall be considered as being northerly or southerly.

(4) SYSTEM. A system of invisible rectangular blocks shall be established as a central grid in the following manner conforming with the recommended uniform address system.

- (a) The established section lines shall form a basis for the block system, and in a westerly direction from the eastern boundary of the County, the first 6 sections, extending through the Towns of Menomonee, Brookfield, New Berlin and Muskego, shall be divided into 16 blocks each. These invisible block lines shall have numerical designations of from "124" at the County line, to "200" at the western Town lines of Muskego, New Berlin, Brookfield and Menomonee. Westward through the remaining towns, the sections shall be divided into 10 blocks each and the block lines shall have numerical designations of from "200" to "400", the latter being at the west edge of the County.

Formatted: Centered

- (b) In a northerly direction from the east west base line, the first and second rows of sections shall be divided into 11 blocks each, the third row into 8 blocks and the fourth row into 9 blocks. >From and including the fifth row northward to the north County line, the sections shall be divided into 8 blocks each. These invisible block lines shall have numerical designations of from "1", the base line, to "96" at the north County line.
- (c) In a southerly direction from the east west base line the first row of sections shall be divided into 13 blocks and the second row into 9 blocks. From and including the third row southward to the south County line the sections shall be divided into 8 blocks each. These invisible block lines shall have the numerical designations of from "1", the base line, to "111" at the south County line.

(5) NUMBERS.

- (a) One hundred numbers shall be assigned to each invisible block, regardless of discrepancies in block sizes. Properties on the north and east sides of streets shall bear even numbers and properties on the south and west sides of streets shall bear odd numbers.
- (b) The number assigned to each property shall be composed of 2 parts. The first part, or street designation, shall be composed of a directional letter, "N", "S" or "W" followed by the appropriate block line.
- (c) The second part of the property number, the block and house designation, shall be composed of directional letter followed by the number of the appropriate block line plus 2 additional digits indicating the relative position of the property in the block.
- (d) For a block which lies south of the east west base line, the designation of the block shall be by the block line numbers of its north and its east boundaries. For a block which lies north of the east west base line, the designation of the block shall be by the block line numbers of its south and its east boundaries.
- (e) Properties and street intersections contained within any block shall bear numbers and directional letters related to the point of intersection of the block boundary lines stipulated in the paragraph next above.

(6) POINT OF DETERMINATION. The point from which any property shall be assigned its proper number shall be determined as follows:

- (a) Where land has been subdivided or platted into lots, the center point of the frontage line of each parcel shall be the point of determination.
- (b) In cases of farm residences or other residences or business places situated on large acreage or away from other development, the point of determination shall be the intersection of the center line of the principal driveway with the street or highway right-of-way line.
- (c) The proper number shall be determined and assigned by the Building Inspector.

(7) STREET NAMES.

~~(a) Streets which are extensions of streets in Milwaukee County shall bear the name by which they are known in that county, excepting that directional prefixes, if any, shall be dropped. No directional prefix shall be used on any local street.~~

~~(b) All numerical street names shall be abandoned and other names substituted.~~

Formatted: Centered

- (ae) A list shall be compiled by the Building Inspector of all existing street names in the Town and no future street shall be given a name which duplicates or approximates an existing name. Cooperation shall be sought with all towns and municipalities in the County to the end that duplication of street names shall be minimized.
- (eb) The Town shall cooperate with neighboring towns, villages and cities to the end that streets which are continuous from one municipality or town to another municipality or town may have but one name when such single name would be desirable.
- (ce) The Town Board may accept or reject proposed names of new streets and, where there is clearly a conflict or duplication in existing names, may direct the changing of one or more such names so that conflict or duplication may be minimized. The Board, if it sees fit, may hold public hearings at which interested property owners may express their views concerning the naming or renaming of a street or streets.

(8) PLAT BOOK.

- (a) The Clerk shall inform any person inquiring of the numbers and approved street names belonging to any property to the degree records will allow, with the Building Inspector making the final determination.
- (b) Within 30 days after the final approval of any new subdivision or other division of land, the Building Inspector shall assign addresses to each new building site. Records shall be kept of the assignments and a copy shall be provided for the developer at his request.

(9) INSTALLATION OF NUMBERS.

- (a) (Repeal & Rec. 99-484) When each residence and place of business has been assigned its respective number, the owner, occupant or agent shall install or cause to be installed those numbers on the premises along the side of the street on which the home sits; in a place clearly visible from the road; ~~no more than 25 feet from the edge of the road pavement; within 10 feet of either side edge of the driveway; and between 2' and 8' above the finished grade at the point of installation.~~
- (b) Numbers shall be installed within 30 days from date of assignment or from the date of initial occupancy.
- (c) (Repeal & Rec. #99-484) The minimum size of the numbers assigned under the uniform address system to be installed shall be 2¼" wide and 3½" high. The letters and numbers assigned shall be black on a white or a reflective background. The numbers shall be installed at a place clearly visible from the traveled portion of the road. Mailboxes may serve to display the house numbers if they are located within 10 ft of the driveway and provided there is no other mailbox adjacent. House numbers displayed on mailboxes must be placed at a height between 2' and 8' above the finished grade at the point of installation. In instances where more than one mail box exists house numbers must also be placed on each individual property as prescribed by the ordinance.

One set of numbers will be sufficient and should be placed parallel to the road. If the house numbers are perpendicular to the road, the numbers must be visible from the travel direction immediately adjacent to the numbers. The owner, occupant, or agent shall install or cause to be installed those numbers on the premises on the side of the street on which the home sits; in a place clearly visible from the road; no more than 25 feet from the edge of the road pavement, within 10 feet of either side edge of the driveway; and between 2' and 8' above the finished grade at the point of installation.

Formatted: Centered

Homes and businesses sharing a common driveway or located on a private road shall have numbers at the intersection with the public road, at each split, fork or intersection thereafter, and on the property itself as specified in this ordinance.

(10) **NUMBERS REQUIRED.** Whenever any residence or place of business shall be erected in the Town after the work of establishing a uniform address system has been completed, the owner shall at the time of obtaining a building permit procure the correct number and street name from the Building Inspector and within 30 days thereafter install the number on the building or premises as provided in sub. (9).

(11) **VIOLATION.** (Repeal & Rec. 99-484) If the owner, occupant, or agent of any residence or place of business shall neglect to comply with the requirements of this ordinance, the Law Enforcement Officer, Building Inspector/Code Enforcement Officer or designated representative of the fire department may issue a notice of non-compliance to the owner, occupant or agent. If the owner, occupant or agent fails to correct the non-compliance within (30) days, the Law Enforcement Officer may issue a citation and the owner, occupant or agent shall be subject to the penalties of Chapter 25 of the Town Code.

8.17 SOLID AND HAZARDOUS WASTE SITING.

(1) The "Siting resolution" authorized by AB-936 is hereby approved.

(2) A Siting Board is hereby established, consisting of 4 members appointed by the Town Board, with no more than 2 elected officials. The Board shall exercise all the authority and obligations granted by AB-936.

8.18 SANITARY SEWER REGULATIONS, FOXWOOD ESTATES SUBDIVISION (Rep. and Recr. Ord. 2007-005)

Formatted: Highlight

(1) INTRODUCTION AND GENERAL PROVISIONS

(a) **INTRODUCTION.** This Ordinance regulates the use of public and private sewers and drains, connections to the public sewer system, discharge of septage into the public sewerage system, and the discharge of waters and wastes into the public sewerage systems within the Foxwood Estates Subdivision within the Town of Delafield. It also provides for and explains the method used for levying and collecting wastewater treatment services charges, sets uniform requirements for discharges into the wastewater collection and treatment systems and enables the said Municipality to comply with administrative provisions, and other discharge criteria which are required or authorized by the State of Wisconsin or Federal law. Its intent is to derive the maximum public benefit by regulating the characteristics of wastewater discharged into the sewerage system.

(b) GENERAL PROVISIONS.

- i. This Ordinance provides a means for regulating the use of the public sewers, effectuating connections thereto, determining wastewater volumes, constituents and characteristics, the setting of charges and fees, and the issuing of permits to certain users. Revenues derived from the application of this Ordinance shall be used to defray the costs of operating and maintaining the wastewater collection and treatment systems and to provide sufficient funds for capital outlay, debt service costs and capital improvements. The charges and fees herein have been established pursuant to requirements of the Wisconsin Statutes.
- ii. This Ordinance shall supersede any previous Ordinances, Rules or Regulations of the Municipality relating to the subject matter hereof; and shall repeal all parts thereof that may be inconsistent with this Ordinance. If there is any conflict between this Ordinance and the inter-municipal agreement between the Town and the Village of Hartland concerning the provision of sanitary sewer service for the Foxwood Estates Subdivision, the terms of said agreement shall control.

(c) **LEGAL AUTHORITY.** This Ordinance is enacted pursuant to the power and authority conferred by Section 66.0821, Stats., as amended from time to time.

Formatted: Centered

(2) DEFINITIONS

Unless the context specifically indicates otherwise, the meaning of terms used in this Ordinance shall be as follows:

- (a) APPROVING AUTHORITY of the Municipality shall mean its Town Board or its duly authorized committee, agent, or representative.
- (b) BUILDING DRAIN shall mean that part of the lowest horizontal piping of a drainage system which receives the discharge from soil, waste, and other drainage pipes inside the walls of the building or structure and conveys it to the Building Sewer.
- (c) BUILDING SEWER shall mean the pipe extension beginning at the outside of the inner face of the building wall, to a point of connection with the public sewer.
- (d) CARBONACEOUS BIOCHEMICAL OXYGEN DEMAND (CBOD) shall mean the quantity of oxygen used in the biochemical degradation of organic material in five (5) days at 20°C when the oxidation of reduced forms of nitrogen is prevented by the addition of an inhibitor. This analytical procedure shall be performed in accordance with Standard Methods.
- (e) COMPATIBLE POLLUTANTS shall mean carbonaceous biochemical oxygen demand, suspended solids, total kjeldahl nitrogen, plus additional pollutants identified in the WPDES permit for the publicly owned treatment works receiving the pollutant if such works were designed to treat such additional pollutants to a substantial degree.
- (f) FLOATABLE OIL shall mean oil, fat, or grease in a physical state such that it will separate by gravity from wastewater by treatment in an approved pretreatment facility. A wastewater or septage shall be considered free of floatable fat if it is properly pretreated and the wastewater does not interfere with the collection of treatment system.
- (g) GARBAGE shall mean the residue from the preparation, cooking, and dispensing of food, and from the handling, storage, and sale of food products and produce.
- (h) GROUND GARBAGE shall mean the residue from the preparation, cooking, and dispensing of food that has been shredded to such degree that all particulates will be no greater than one-half (1/2) inch in any dimension and will be carried freely in suspension under normal flow conditions in sewers.
- (i) INCOMPATIBLE POLLUTANTS OR WASTEWATER shall mean wastewater or septage with pollutants of such a strength that will adversely affect or disrupt the wastewater treatment processes or effluent quality or sludge quality if discharged to the sewerage system facility.
- (j) INDUSTRIAL WASTE shall mean the wastewater from an industrial process, trade, or business, as distinct from sanitary sewage, including cooling water and the discharge from sewage pretreatment facilities.
- (k) MAY is permissible.
- (l) DEL-HART ORDINANCE shall mean the Sewer Use & User Charge Ordinance of the Delafield-Hartland Water Pollution Control Commission (herein the "Del-Hart Commission") effective February 27, 2007, and any amendments thereto or restatements thereof.
- (m) MUNICIPAL WASTEWATER shall mean the wastewater of a municipality, including that of the Municipality. From the standpoint of source, it may be a combination of the liquid and water-carried wastes from residential, commercial buildings, industrial plants and

institutions, together with any groundwater, surface water, and storm water that may have inadvertently entered the sewerage system of the municipality.

- (n) MUNICIPALITY shall mean the Town of Delafield, a Wisconsin municipality.
- (o) NATURAL OUTLET shall mean any outlet, including storm sewers, into a water course, pond, ditch, lake or other body of surface water or groundwater.
- (p) PARTS PER MILLION shall mean a weight-to-weight ratio; the parts per million value multiplied by the factor 8.34 shall be equivalent to pounds per million gallons of water.
- (q) PERSON shall mean any and all persons, including any individual, firm, company, municipal or private corporation, association, society, institution, enterprise, government agency, or other entity.
- (r) pH shall mean the logarithm of the reciprocal of hydrogen ion concentration. The concentration is the weight of hydrogen ions, in grams per liter of solution. Neutral water, for example, has a pH value of 7 and a hydrogen ion concentration of 10^{-7} .
- (s) PUBLIC SEWER shall mean any sewer owned or provided by or subject to the jurisdiction of the Municipality, the Del-Hart Commission or any other municipality.
- (t) SANITARY SEWAGE shall mean a combination of liquid and water-carried wastes discharged from toilets and/or sanitary plumbing facilities, together with such ground, surface, and storm waters as may have inadvertently entered the sewerage system.
- (u) SANITARY SEWER shall mean a sewer that carries liquid and water-carried wastes from residences, commercial buildings, industrial plants, and institutions, together with small quantities of ground, storm, and surface waters that are not admitted intentionally.
- (v) SEPTAGE shall mean the wastewater or contents of septic or holding tanks, dosing chambers, grease interceptors, seepage beds, seepage pits, seepage trenches, privies or portable restrooms.
- (w) SEWER SERVICE CHARGE is a service charge levied on users of the wastewater collection and treatment facilities for payment of use-related capital expenses as well as the operation and maintenance costs, including replacement costs, of said facilities.
- (x) SEWER SYSTEM means the public sanitary sewers within a sewerage system. The facilities which convey wastewater from individual structures, from private property to the public sanitary sewer, or its equivalent, are specifically excluded from the definition of "sewer system"; except that pumping units and pressurized lines for individual structures or groups of structures may be included as part of a "sewer system" when such units are owned and maintained by the Municipality or the Village of Hartland. For example, a Building Sewer is not part of the sewer system.
- (y) SEWERAGE SYSTEM means all structures, conduits and pipes, by which sewage is collected, treated, and disposed of, except plumbing inside and in connection with buildings served, and service pipes, from building to street main, i.e., a Building Sewer.
- (z) "SHALL" is mandatory.
- (aa) SLUG LOAD shall mean any substance released at a discharge rate and/or concentration which causes interference to wastewater treatment processes or plugging or surcharging of the sewer system.
- (bb) STATS. shall mean the Wisconsin Statutes in effect from time to time.

- (cc) STANDARD METHODS shall mean the examination and analytical procedures set forth in the most recent edition of "Standard Methods for the Examination of Water, Sewage, and Industrial Wastes" published jointly by the American Public Health Association, the American Water Works Association and the Water Pollution Control Federation and is in compliance with Federal Regulations 40 CFR 136, "Guidelines Establishing Test Procedures for Analysis of Pollutants," all as amended from time to time.
- (dd) STORM DRAIN (sometimes termed "STORM SEWER") shall mean drain or sewer for conveying surface water, groundwater, ~~subsurface~~ and subsurface water other than polluted water from any source.
- (ee) STORM WATER RUNOFF shall mean that portion of the rainfall that is collected and drained into the storm sewers.
- (ff) SUSPENDED SOLIDS shall mean solids that either float on the surface of, or are in suspension in, water, wastewater, septage, or other liquids, and that are removable by laboratory filtering as prescribed in "Standard Methods" and is referred to as non-filterable residue.
- (gg) TOTAL KJELDAHL NITROGEN (TKN) shall mean the quantity of organic nitrogen and ammonia as determined in accordance with Standard Methods.
- (hh) TOTAL PHOSPHOROUS (TP) shall mean the quantity of total phosphorous as determined in accordance with the Standard Methods.
- (ii) WASTEWATER FACILITIES shall mean the structures, equipment, and processes required to collect, carry away, store, and treat domestic and industrial waste and septage and dispose of the effluent and sludge.
- (jj) WASTEWATER TREATMENT WORKS shall mean an arrangement of devices and structures for treating wastewater, septage, industrial waste, and sludge. Sometimes use is synonymous with waste treatment facilities.
- (kk) WATERCOURSE shall mean a natural or artificial channel for the passage of water, either continuously or intermittently.

(3) MANAGEMENT, OPERATION, AND CONTROL

- (a) MANAGEMENT. The management, operation, and control of the sewer system for the Municipality is vested in the Town Board and the Village Board of the Village of Hartland pursuant to the inter-municipal agreement between the Village of Hartland and the Town of Delafield concerning sanitary sewer service for the Foxwood Estates Subdivision on file in the office of the Town Clerk.
- (b) OWNER'S MAINTENANCE OF BUILDING SEWER. The owner of property abutting a public sewer shall maintain sewer service from the public sewer main to the structure or building on the owner's property, including all controls between the same, without expense to the Municipality, except when they are damaged as a result of negligence or carelessness on the part of the Municipality. Without intending to limit the generality of the foregoing, the owner has the sole responsibility for the repair and maintenance of all Building Sewers; and the ownership thereof shall at all times be vested in such property owner. All sewer services must be maintained free of defective conditions, by and at the expense of the owner or occupant of the property. When any sewer service is to be ~~relaid~~ re-laid and there are two or more buildings on such service, each building shall be disconnected from such service and a new sewer service shall be installed for each building. In the event of any obstruction of, damage to or repair of a Building Sewer, the same shall be the responsibility of the property owner, except as provided for in Section 4(f) hereof or as otherwise provided for herein.

- (c) TITLE TO REAL ESTATE AND PERSONAL PROPERTY. All property, real, personal, and mixed, including but not limited to easements, acquired for the construction of the Municipality's sewer system, and all plans, specifications, diagrams, papers, books and records connected therewith, and all buildings, machinery, and fixtures pertaining thereto, shall be the property of and titled in the name of the Village of Hartland in accordance with the inter-municipal agreement between the Town and the Village of Hartland concerning sanitary sewer service for the Foxwood Estates Subdivision .
- (d) NO LIMITATION. Nothing contained in this Ordinance shall be construed as limiting the power and authority of the Municipality as provided for by applicable Wisconsin Statutes; and the Municipality shall have all rights and authority as provided for by law.

(4) ADMINISTRATIVE RULES AND REGULATIONS

The following rules, regulations and ordinances for the regulation of licensed plumbers, sewer users, property owners and others, are hereby adopted and established:

- (a) GENERAL PROVISIONS
- i. Agreement to Rules and Regulation. All persons now receiving sewerage service from the Municipality or who may hereafter make application for such service or who otherwise receive such service, shall be considered as having agreed to be bound by all of the terms and provisions of this Ordinance, as amended from time to time; and such agreement is a condition precedent to the provision of such sewerage service.
 - ii. Application for Service. Every person desiring to connect property, buildings or structures to public sewers shall make application in writing to the Municipality on such forms as are prescribed for that purpose, prior to commencing use of such service. The application must describe fully and truthfully all the wastes which are anticipated to be discharged. If the applicant is not the fee simple owner of the property, the written consent of the owner must accompany the application. Persons connected to the public sewers of the Municipality are referred to herein as "Users." By submitting such an application, all users are deemed to have agreed to be bound by this Ordinance, as amended from time to time. If it appears that the service applied for will not provide adequate service for the contemplated use, the Municipality may reject the application. If the Municipality approves the application, it shall issue a connection permit as shown on the application. No service shall be provided or application approved without prior payment of all applicable fees.
 - iii. Application Fee. Where the application for service is for a connection to the Municipality's public sewers, the application shall be accompanied by an Application Fee(s) in an amount to be determined from time to time by the Municipality. Such fee shall cover the cost of processing the application and inspection of the connection. Application Fees may vary in amount between residential users and commercial/industrial users. The payment of this fee shall be in addition to any Connection Fees that may be charged to or on account of new users by the Municipality, the Village of Hartland, or by the Del-Hart Commission.
 - iv. Inspections. Any connection to the public sewers within the Municipality shall be subject to the prior inspection and approval of the work by an authorized representative of the Municipality and/or the Village of Hartland. No trench or other excavation shall be filled, or any connection completed, without such prior inspection. The applicant requesting the connection shall reimburse the Municipality for all inspection costs incurred, if not previously paid as part of the Application Fee.
 - v. Disconnection and Refusal of Service. Sewer service may be disconnected or refused for any of the following reasons:

- (1) Violation of this Ordinance, as amended from time to time;
 - (2) Violation of the Del-Hart Ordinance, as amended from time to time;
 - (3) Failure to pay the Application Fee, any Connection Fee or delinquent sewer service charges of the user.
 - (4) Violation of the inter-municipal agreement between the Town and the Village of Hartland concerning sanitary sewer service for the Foxwood Estates Subdivision.
- vi. Disconnection for Delinquent Accounts or Where a Dangerous Condition Exists. A bill for service is delinquent if unpaid after the due date shown on the bill. The Municipality may disconnect service for a delinquent bill by giving the user, at least eight calendar days prior to disconnection, a written disconnect notice which may be included in the bill for service. For purposes of this rule, the due date shall not be less than twenty days after issuance of the bill. The Municipality or the Village of Hartland may disconnect without notice where the Village Engineer, Town Engineer, or Del-Hart's Engineer reasonably determines in his or her opinion that that disconnection is necessary to avoid danger to persons or property due to a condition that exists on the property. The Municipality may thereafter deny reconnection of service for as long as the condition exists.
- vii. Denial of Service Due to Non-Compliance or Dangerous or Unsafe Conditions. Service may be denied to any user for failure to comply with the applicable requirements of this Ordinance or if the Village Engineer, or the Village Engineer's designee, has reasonably determined that a dangerous or unsafe condition exists on the user's property.
- (b) PLUMBERS. No plumber, pipe fitter, or other person will be permitted to do any plumbing or pipe fitting work in connection with the sewer system without first receiving a license from the State of Wisconsin and obtaining permission from the Municipality in which the work is to be performed. All service connections to the sewer main shall comply with the State plumbing code, as amended.
- (c) MANDATORY CONNECTIONS
- i. Within that portion of the Foxwood Estates Subdivision receiving sanitary sewer service from the Village of Hartland, the owner of each parcel of land adjacent to a public sewer main on which there exists a building used or usable for human habitation or in a block through which such system is extended, shall connect to the sewer system within 365 days (one year) of notice in writing from the Municipality. Upon failure to do so, the Municipality may cause such connection to be made and bill the property owner for all such costs. If such costs are not paid within thirty (30) days, such cost shall constitute a special tax lien against the property, in the manner provided for by law. However, the owner may within thirty (30) days after the completion of the work file a written election with the Municipality stating that the owner cannot pay such amount in one sum and ask that the sum be levied in five (5) or less equal annual installments. The amount shall be so collected with interest at a rate not to exceed fifteen percent (15%) per annum from the date of completion of the work, all as determined by the Municipality. The unpaid balance shall constitute a special tax lien, all pursuant to sec. 281.45, Stats., as amended.
 - ii. This Ordinance ordains that, where sanitary sewer service is available within the Foxwood Estates Subdivision pursuant to inter-municipal agreement between the Town and the Village of Hartland concerning sanitary sewer service for the Foxwood Estates Subdivision, any such failure to connect to such sewer system is contrary to the minimum health standards of the Municipality and fails to assure preservation of public health, welfare, comfort, and safety; and that such failure constitutes a public nuisance under sec. 823.02, Stats., as amended, subject to abatement as provided for therein.

- (d) BUILDING SEWER CONNECTION EXPENSE. Persons attaching to a public sewer shall have the Building Sewer, or lateral, installed at their own cost and expense.
- (e) TAP PERMITS. After sewer connections have been introduced into any building or upon any premises, no plumber shall make any alterations, extensions, or attachments, unless the party ordering such tapping or other work exhibits the proper permit for the same from the Municipality.
- (f) OBSTRUCTION OF BUILDING SEWERS IN PUBLIC RIGHT OF WAYS. In the event of any blockage, damage or break in any Building Sewer, which occurs within a public street, alley, highway, or other public right of way, the Village of Hartland shall have the exclusive right and option to repair the Building Sewer within said street, alley, highway, or right of way. In such event, the owner of the Building Sewer shall promptly reimburse the Municipality and/or the Village of Hartland for all costs so incurred. If not so reimbursed, the same shall be added to the owner's sewer service charges and collected in the same manner as such charges are so collected.
- (g) BACKFLOW PREVENTER. All floor drains shall have a backflow prevention valve installed at the owner's expense.
- (h) USER USE ONLY. No user shall allow other persons or other services to connect to the sewer system through their lateral or Building Sewer.
- (i) USER TO PERMIT INSPECTION. Every user shall permit the Municipality, the Village of Hartland, or its duly authorized agent, at all reasonable times, to enter their premises or building to examine the pipes and fixtures, and the manner in which the drains, and sewer connections operate; and the user must at all times, frankly and without concealment, answer all questions put to them relative to its use, all in accordance with this Ordinance and sec. 196.171, Stats., to the extent applicable.
- (j) MUNICIPAL RESPONSIBILITY. It is expressly stipulated that no claim shall be made against the Municipality or its Board members, agents, employees and representatives by reason of the breaking, clogging, stoppage, or freezing of any pipes; nor from any damage arising from repairing mains, making connections or extensions or any other work that may be deemed necessary. The right is hereby reserved to cut off sewer service at any time for the purpose of repairs or any other necessary purpose, any permit granted or regulations to the contrary notwithstanding.
- (k) EXCAVATIONS WITHIN PUBLIC RIGHT OF WAY. Any person excavating in the public right of way shall fully comply with all provisions of Section 8.02 of the Municipal Code.
- (l) TAPPING THE MAINS. Connections to the sewer system, other than Building Sewer connections, shall be done only in accordance with the Del-Hart Ordinance, as amended.
- (m) INSTALLATION OF BUILDING SEWERS. All Building Sewers on private property shall be installed in accordance with State of Wisconsin Administrative Code "Design, Construction, Installation, Supervision, and Inspections of Plumbing," especially, Section ILHR 82.10, "Basic Plumbing Principles," as amended. As required therein, all laterals shall be inspected. The Building Sewer and/or private interceptor main sewer shall be inspected upon completion of placement of the pipe and before backfilling and tested before or after backfilling.
- (n) APPLICATION OF DEL-HART ORDINANCE. Notwithstanding anything to the contrary contained herein, any connection to the public sewers shall be subject to the provisions of the Del-Hart Ordinance, as amended from time to time, to the extent

Formatted: Centered

applicable and to the inter-municipal agreement between the Town and the Village of Hartland concerning sanitary sewer service for the Foxwood Estates Subdivision. In the event of any conflict between the provisions of the Del-Hart Ordinance, the more restrictive provision shall control.

- (o) NEW CONNECTIONS. New connections to the Municipality’s sewer system will be allowed only if there is available capacity in all of the downstream wastewater collection and treatment facilities of the Municipality and the Del-Hart Commission and such connection is permitted under the Town’s inter-municipal agreement with the Village of Hartland concerning sanitary sewer service for the Foxwood Estates Subdivision.

(5) USE OF THE PUBLIC SEWER

- (a) NO CLEAR WATER DISCHARGES. No person shall discharge or cause to be discharged any unpolluted waters such as storm water, ground water, roof rain, subsurface, drainage or collecting water to any sanitary sewer.
- (b) COMPLIANCE WITH THE DEL-HART ORDINANCE. No person shall discharge wastes into a public sewer within the Municipality, except residential wastes in accordance with the provisions of the Del-Hart Ordinance, as amended from time to time.
- (c) NO DISCHARGE TO VIOLATE GENERAL PERMIT FOR BYPASSING. No person shall discharge or cause to be discharged any waters, wastewaters or other substances of any kind or nature that will result in or otherwise cause a violation of any General Permit For Bypassing issued by the Wisconsin Department of Natural Resources and held by the Municipality.

(6) PUBLIC SEWER MAIN EXTENSIONS

- (a) APPLICATION AND APPROVAL. The extension of public sewer mains to serve new customers/users is subject to the prior review and approval of the Municipality, the Village of Hartland, and any other governmental agency having appropriate jurisdiction thereof. Any person seeking to develop real property and requiring sewer service in connection with such development, shall make application to the Municipality for a public sewer main extension, if so required in order to serve such development. Such application shall be in writing and shall set forth the following information:
 - i. Name of development and the legal description of the property involved.
 - ii. Plat map or certified survey map or other map showing street layout and lot sizes.
 - iii. Zoning of the property.
 - iv. Proposed plans and specifications for the sewers.
 - v. Name and address of consulting engineer.
 - vi. Number of housing units and/or other units to be constructed.
 - vii. Such additional information as the Municipality may require.
- (b) CONDITIONS OF APPROVAL. The Municipality, subject to its inter-municipal agreement with the Village of Hartland concerning sanitary sewer service for the Foxwood Estates Subdivision, shall have the discretion to approve or disapprove the

Formatted: Centered

requested public sewer main extensions. In granting such approval, the Municipality may condition its approval upon compliance with:

- i. Any applicable ordinances of the Municipality, the Del-Hart Commission or Waukesha County.
- ii. Any applicable statute, rules, orders, or codes of the State of Wisconsin.
- iii. The preparation of plans and specifications for the sewer main extension, subject to the approval of the Municipality and its consulting engineer.
- iv. The applicant making and installing the public sewer main extension at his/her/its sole cost and expense or otherwise providing a surety bond or other security to ensure that the main will be so constructed within a reasonable period of time.
- v. The dedication of such rights of way, easements and sewerage facilities as the Municipality may reasonably require.
- vi. The payment of all costs and expenses incurred or to be incurred by the Municipality in connection with the review and approval of such sewer extension, including but not limited to engineers fees, attorneys fees, inspection fees and other similar costs and expenses.
- vii. The payment of any applicable Connection Fees due or to become due pursuant to the inter-municipal agreement between the Town and the Village of Hartland concerning sanitary sewer service for the Foxwood Estates Subdivision.
- viii. Any restriction or condition set forth in the inter-municipal agreement between the Town and the village of Hartland concerning sanitary sewer service for the Foxwood Estates Subdivision.
- ix. Any other condition determined by the Municipality to be fair and reasonable in order to protect the interest of the Municipality in connection with the proposed development.

- (c) CONTRACT FOR SEWER IMPROVEMENTS. The Municipality may require the person filing an application pursuant to Section 6(a) hereof, to enter into a written development agreement with the Municipality, as a condition of the approval of the sewer main extension. Such agreement shall define the scope of the work, the obligations of the applicant to construct the sewer facilities, the requirement of security for performance of the applicant's obligations set forth therein, and such other matters as the Municipality may reasonably determine. The applicant shall reimburse the Municipality for all fees and costs as provided for in Section 3.08 of the Town ordinances.

(7) SEWER USER CHARGE SYSTEM

Sewer service charges, costs, and fees to each user shall be based on the inter-municipal agreement between the Municipality and the Village of Hartland concerning sanitary sewer service for the Foxwood Estates Subdivision.

(8) CONTROL OF INDUSTRIAL WASTES

- (a) GENERAL
 - i. An "Industrial Discharge" or "Industrial Waste" shall have the same meaning as provided for in the Del-Hart Ordinance, as amended from time to time.
 - ii. No person shall discharge or cause discharge of Industrial Waste into the public sewers of the Municipality.

(b) DISCHARGE OF HOLDING TANK WASTE

- i. GENERAL. For purposes of this Section, the terms "Holding Tank Waste" and "Licensed Disposer" shall have the same meaning as provided for in the Del-Hart Ordinance, as amended from time to time.
- ii. PROHIBITION OF DISCHARGE INTO THE MUNICIPALITY'S PUBLIC SEWERS. No person, including a Licensed Disposer, shall discharge any Holding Tank Waste, or any other similar waste, into any manhole or other opening in a public sewer owned or maintained by the Municipality. Instead, all such discharges of Holding Tank Wastes shall be made pursuant to the Del-Hart Ordinance, as amended from time to time.

(10) BILLING AND PAYMENT OF SEWER SERVICE CHARGES

- (a) CALCULATION. Sewer Service Charges that are to be assessed to users shall be computed by the Municipality according to the rates and methodology presented in Chapter VII of this Ordinance.
- (b) BILLING. Sewer Service Charges shall be billed to each user as provided for in the inter-municipal agreement between the Town and the Village of Hartland concerning sanitary sewer service for the Foxwood Estates Subdivision.
- (c) PENALTY FOR DELINQUENT PAYMENTS. A penalty equal to one and one-half (1.5%) percent per month of the delinquent amount shown on any bill for services, shall be added to all bills not paid by the date fixed therein for final payment. An additional penalty of ten (10%) shall be assessed and delinquent bills placed on the tax roll pursuant to the provisions set forth in Section 66.0809(3), Wis. Stats.
- (d) REMEDIES FOR FAILURE TO MAKE PAYMENTS. The Municipality may direct that unpaid Sewer Service Charges, Connection Fees, or other charges due from any person or user, shall be collected and taxed and shall be a lien upon the property served in the manner provided for in Sections 66.0809 and 66.0821(4)(d), Stats., as amended from time to time, or the Municipality may utilize any other remedy available to it under Wisconsin law..
- (e) OBLIGATION FOR PAYMENT. The obligation for payment of Sewer Service Charges, Connection Fees or other charges due the Municipality shall be a joint and several obligation of the user and property owner, where the user and property owner are not the same person. To the end that there may be attempts at avoidance of payment of such charges and fees by non-property owner users, and to overcome the same, the Municipality or Village of Hartland may send the bill for such a user, in care of the property owner.
- (f) REMEDIES CUMULATIVE. All remedies provided for in this Ordinance are distinct and cumulative to any other right or remedy under this Ordinance or any other Ordinance of the Municipality or afforded by law or equity; and may be exercised by the Municipality concurrently, independently, or successively.

(11) CONNECTION FEES

For each connection of a Building Sewer to a public sewer within the Foxwood Estates Subdivision, there shall be paid a Connection Fee as determined pursuant to inter-municipal agreement between the Town and the Village of Hartland concerning sanitary sewer service for the Foxwood Estates Subdivision. The failure to pay any Connection Fee is a violation of this Ordinance; and this Municipality may pursue all rights and remedies provided for herein.

(12) VIOLATIONS, ABATEMENT PROCEDURES AND PENALTIES

- (a) VIOLATIONS CONSTITUTING PUBLIC NUISANCE. A violation (other than the failure to pay Sewer Service Charges or other fees or costs due under this Ordinance) of any provision of this Ordinance or any other rule or order of the Municipality is hereby declared to be a public nuisance.
- (b) DAMAGE TO MUNICIPALITY'S PROPERTY. No person shall maliciously, willfully, or negligently break, damage, destroy, uncover, deface, or tamper with any structure of equipment which is a part of the Municipality's or Village of Hartland's sewerage system. Any person violating this provision shall be subject to immediate arrest under charge of disorderly conduct or criminal damage to property as the case may be.
- (c) ENFORCEMENT. The Municipality shall have the right to enforce the provisions of this Section and shall make periodic inspections and inspections upon complaint to insure that such provisions are not violated. No action shall be taken under this Section to abate a public nuisance unless the Municipality and/or the Village of Hartland shall have inspected or caused to be inspected the premises where the nuisance is alleged to exist and shall have satisfied itself that a nuisance does in fact exist.
- (d) OTHER METHODS NOT EXCLUDED. Nothing in this Ordinance shall be construed as prohibiting the abatement of public nuisances by the Municipality or its officials in accordance with the laws of the State of Wisconsin.
- (e) COURT ORDER. Except where otherwise permitted under applicable Wisconsin law, the Municipality shall not use force to obtain access to private property to abate a public nuisance, but shall request permission to enter upon private property if such premises are occupied, and, if such permission is denied, shall apply to any court having jurisdiction for an order assisting the abatement of public nuisance.
- (f) COST OF ABATEMENT. In addition to any other penalty imposed by this Chapter for the erection, contrivance, creation, continuance or maintenance of a public nuisance, the cost of abating a public nuisance by the Municipality shall be collected as a debt from the owner, occupant, or person causing, permitting, or maintaining the nuisance, and such cost shall be assessed against the real estate as a special charge. For purposes hereof, costs shall include but not be limited to actual attorneys' fees and court costs.
- (g) Section 13.9 CONTINUED 13.9 CONTINUED VIOLATIONS. Any person who shall continue any violation beyond the aforesaid notice time limit provided, shall be subject to penalties as provided in § 25.04 of this Code and shall be liable for any expense, loss or damage occasioned the Town, commission, or others by reason of such violation, including any costs in connection with repairing damages to the wastewater facilities or any downstream user or facilities damaged as a result of a prohibited discharge or any violation of this section.
- (h) ACCIDENTAL DISCHARGE. Any person found to be responsible for accidentally allowing a deleterious discharge into the sewerage system which causes damage to the sewerage system and/or a receiving body of water (e.g., lake, river, stream, etc.) shall, in addition to a fine, pay the amount to cover all damages, both of which will be determined by the Municipality or other governmental authority having appropriate jurisdictions.
- (i) ACCIDENTAL DISCHARGE REPORTING. Any person responsible for an accidental discharge that may have a detrimental impact on the sewerage system, shall immediately report the nature and amount of the discharge to the Del-Hart Commission.

Formatted: Centered

- (j) **LIABILITY FOR LOSSES.** Any person violating any provision of this Ordinance shall become liable to the Municipality for any expense, attorney's fees, costs, engineering fees, loss, or damage occasioned by reason of such violation which the Municipality may suffer as a result thereof. Without intent to limit the generality of the foregoing, the Municipality shall have the right of recovery from all such persons, any expense incurred by the Municipality for the repair or replacement of any part of the public sewerage system damaged in any manner by any person by the performance of any work under its control, or by any negligent acts.

(13) **SEPTIC SYSTEMS**

The maintenance and use of a septic tank or other private sewerage disposal system by any owner of land located within the Foxwood Estates Subdivision serviced by the Village of Hartland pursuant to the inter-municipal agreement between the Town and the Village of Hartland concerning sanitary sewer service for the Foxwood Estates Subdivision, is hereby declared to be a public nuisance and a health hazard. Such nuisance and hazard shall be abated; and damages and costs recovered therefor in accordance with Section 823.02 of the Wisconsin Statutes.

8.20 PENALTY. Any person who shall violate any provision of this chapter or any order, rule or regulation made hereunder shall be subject to a penalty as provided in §25.04 of this General Code.

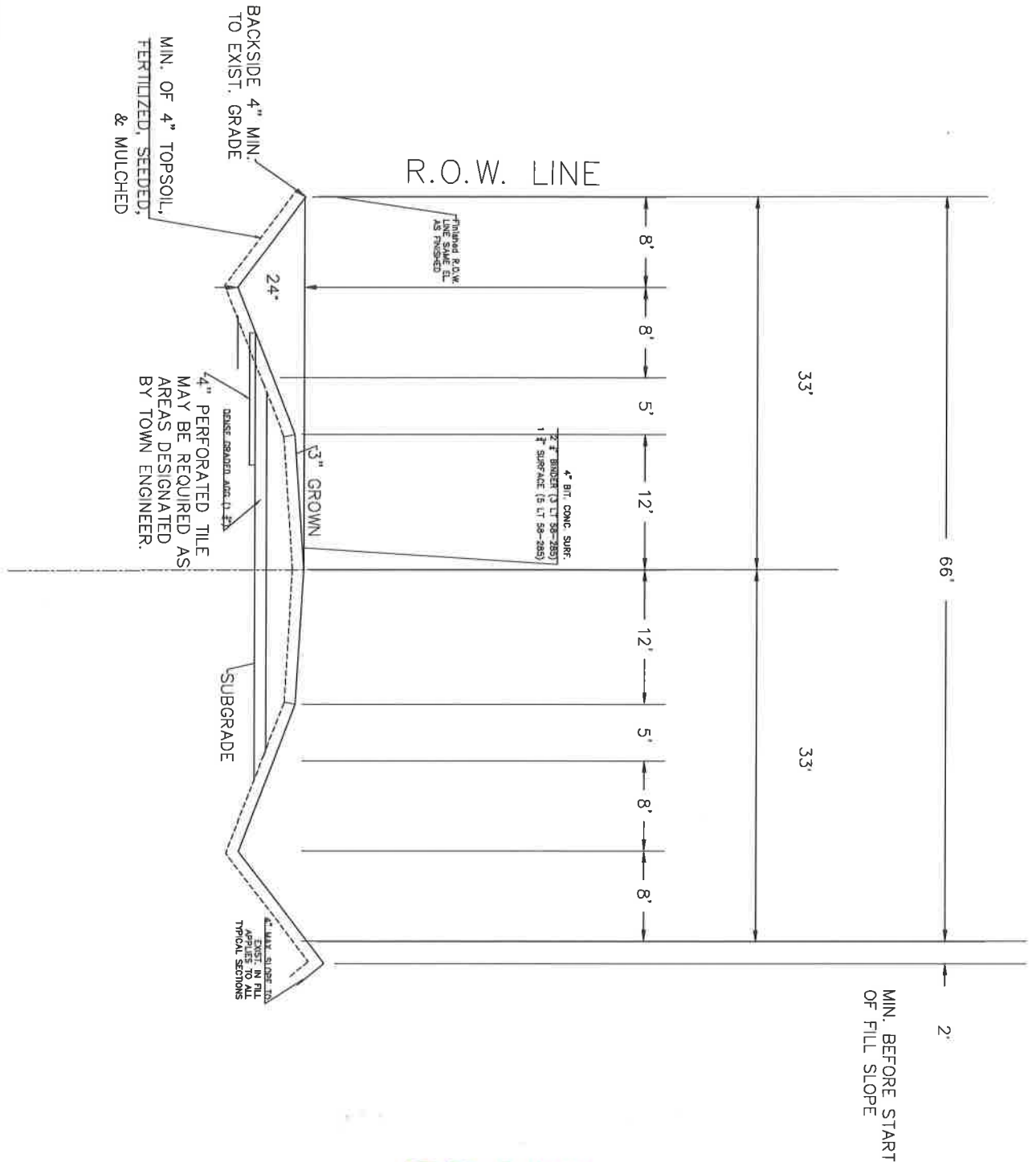

Notes:
 1. CURB AND GUTTER MEETING THE REQUIREMENTS OF EXHIBIT "A" SHALL BE INSTALLED ON THE INSIDE RADIUS OF ALL CURVE LINEAR ROADS AND AT ALL RADII OF INTERSECTIONS.

DRAFT

 <p>16745 W. Bluemound Road Brookfield, WI 53005-5938 (262) 781-1000 rasmith.com</p>	TOWN OF DELAFIELD STANDARD DETAILS		© COPYRIGHT 2021 R.A. Smith, Inc. DATE: 7/21 SCALE: NOT TO SCALE JOB NO. 1211600 PROJECT MANAGER: TGB
	MINOR STREET		SHEET NUMBER Ex A

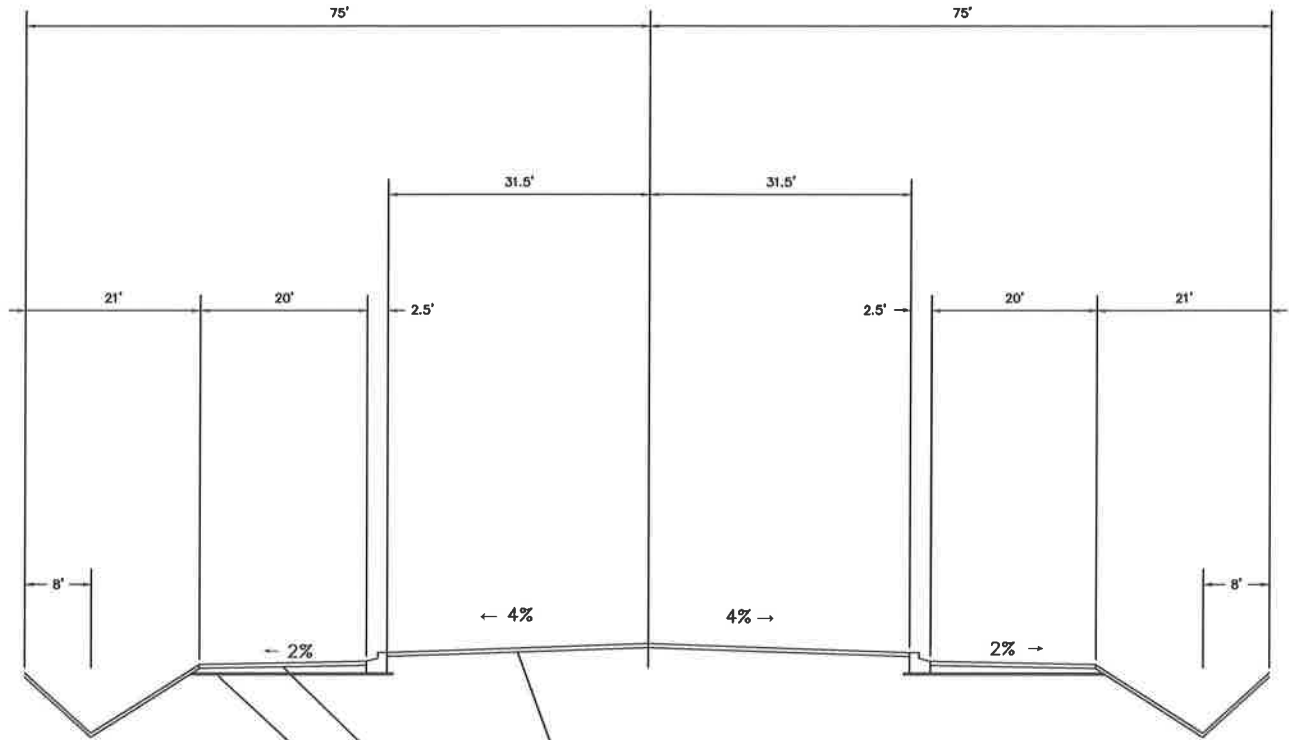

MIN OF 4" TOPSOIL,
SEED, FERTILIZER &
MULCH

4" BIT. CONC. SURF.(2 1/4" Binder 3 LT 58-28 S)
(1 3/4" SURFACE 5 lt 59-28 S)

10" DENSE GRADED AGGREGATE (1 1/4")

(NOT TO SCALE)

DRAFT

raSmith
CREATIVITY BEYOND ENGINEERING

16745 W. Bluemound Road
Brookfield, WI 53005-5938
(262) 781-1000
rasmith.com

Brookfield, WI | Milwaukee, WI | Appleton, WI | Madison, WI
Cedarburg, WI | Naperville, IL | Irvine, CA

**TOWN OF DELAFIELD
STANDARD DETAILS**

**TYP.
CUL-DE-SAC**

© COPYRIGHT 2021
R.A. Smith, Inc.

DATE: 7/21

SCALE: NOT TO SCALE

JOB NO. 1211800

PROJECT MANAGER:
TGB

SHEET NUMBER

5x B

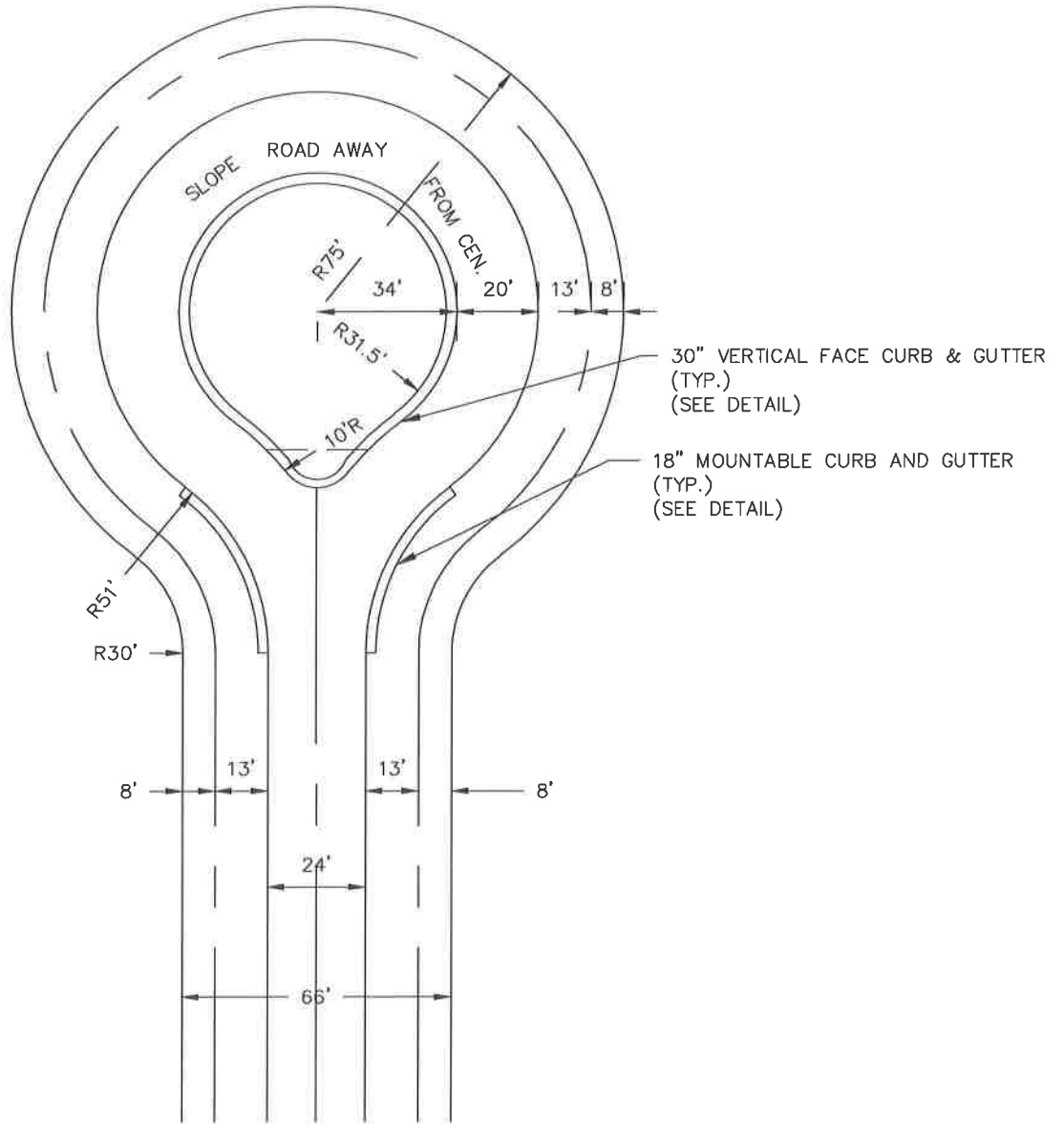

- NOTES:
 1. DITCH SLOPE AROUND CUL-DE-SAC BULB SHALL BE MINIMUM 1.5%

DRAFT



16745 W. Bluemound Road
 Brookfield, WI 53005-5938
 (262) 781-1000
 rasmith.com

Brookfield, WI | Milwaukee, WI | Appleton, WI | Madison, WI
 Cedarburg, WI | Naperville, IL | Irvine, CA

**TOWN OF DELAFIELD
 STANDARD DETAILS**

CUL-DE-SAC

© COPYRIGHT 2021 R.A. Smith, Inc.
DATE: 7/21
SCALE: 1"=40'
JOB NO. 1211600
PROJECT MANAGER: TGB
SHEET NUMBER Ex C

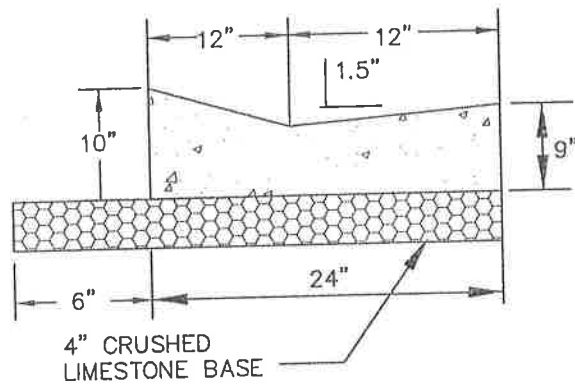

24" MOUNTABLE CURB
 DETAIL
 N.T.S.

DRAFT

STATE OF WISCONSIN

TOWN OF DELAFIELD

WAUKESHA COUNTY

ORDINANCE NO. 2021-09

AN ORDINANCE TO REPEAL AND RE-CREATE PORTIONS OF CHAPTER 8 OF THE TOWN OF DELAFIELD TOWN CODE TO UPDATE THE LANGUAGE TO BETTER ENCOMPASS THE INTENT OF THE TOWN

WHEREAS, the Town of Delafield has a Town Code that creates certain rules and regulations relating to public works in the Town; and

WHEREAS, the Town Staff has updated the Town Code to better fit the needs of the Town; and

WHEREAS, these changes have not yet been incorporated into the Town of Delafield Town Code.

NOW, THEREFORE, the Town Board of the Town of Delafield, Waukesha County, Wisconsin, DOES HEREBY ORDAIN AS FOLLOWS:

SECTION 1: Chapter 8 of the Town of Delafield Town Code entitled "Public Works", Section 8.02 entitled "Driveways and Culverts", is hereby repealed and re-created as follows:

8.02 DRIVEWAYS AND CULVERTS.

(1) CULVERTS TO BE INSTALLED. (Am. #88-200) No driveway shall be constructed or maintained connecting with any street unless a suitable culvert is first installed across the roadside ditch at the street, where necessary. The culvert shall be set to the finished grade as established or at the grade established by the Town Highway Superintendent. Such culvert shall be constructed of corrugated metal pipe and shall have a cross section of not less than that of a 15" pipe. The length of the culvert shall be as required by the Town Highway Superintendent and shall be installed by the Highway Superintendent. All culverts shall be equipped with end guards made of concrete or steel and shall be so installed as to not be beyond street height. Any person who wishes to have a culvert installed on any Town road shall first make application therefor with the Town Highway Superintendent. The applicant shall deposit a fee equal to the estimated cost of installation. The culvert and end sections shall be provided by the applicant and installed by the Town Highway Superintendent. On any county or State highway, application shall be made to the Waukesha County Highway Department. ~~No concrete surfacing shall be installed over any culvert within the road right-of-way.~~

(2) EXISTING DRIVEWAYS. Where the public welfare requires a suitable culvert for an existing driveway, the Town Board shall notify, in writing, the property owner maintaining the driveway across any gutter in any street, that the Town will install a culvert at the expense of the abutting property. The property owner shall deposit a sum in an amount equal to the estimated cost of installing such culvert within 10 days from date of notice. If the deposit is not made, the cost of the installation will be charged to the abutting property and, if not paid to the Town Treasurer on or before November 1, shall be entered on the tax roll as a special tax against the property.

(3) FINANCIAL GUARANTEES REQUIRED FOR LANDSCAPING OF ROADSIDE DITCHES. (rep. & rec. 17-626)

(a) Guarantee Specifications. All applications for a private driveway culvert installation shall include a cash deposit, letter of credit or bond in the amount set forth from time to time by resolution of the Town Board to insure proper completion of the landscaping

restoration of the roadside ditch, in addition to the cost for such installation. This cash deposit, letter of credit or bond shall be for the roadside ditch adjacent to the culvert installation, shall be in a form approved by the Town Attorney, and shall be specifically applicable to the property for which a private driveway or culvert installation application has been made and shall not cover any other property. The cash deposit, letter of credit or bond will be held by the Town until the roadside ditch landscape restoration has been completed and approved by the Town Highway Superintendent~~Building Inspection Department~~ or authorized designee.

(b) Inspection for Return of Guarantee. The property owner may request return of the financial guarantee required in subsection (a) at any time upon completion of the culvert installation and landscaping restoration. Upon such request, the Town Highway Superintendent~~Building Inspector~~ or authorized designee shall make an inspection of the installation and restoration and if properly restored and landscaped, shall authorize return of the financial guarantee. If no request is made for an inspection within a year of the installation of the culvert, the Town shall make an inspection of the culvert and roadside ditch adjacent thereto, and if such installation is in proper condition and the landscaping and restoration of the ditch and culvert are properly completed as determined by the Town Highway Superintendent~~Building Inspector~~ or authorized designee, then the financial guarantee shall be returned to the owner.

(c) Unsatisfactory Landscape/Repair. If any work needs to be done on the landscaping or any restoration of the ditch or repair of any damage due to construction or erosion in the opinion of the Town Highway Superintendent~~Building Inspector~~, this work shall be done by the Town and the property owner shall be billed therefore by the Town. If such bill is not paid within 30 days, the amount thereof shall be charged to the financial guarantee provided by the owner and the balance thereof shall be released by the Town to the property owner as herein provided.

(4) SURFACING OF PRIVATE DRIVEWAYS AND TOWN RIGHT-OF-WAYS. (rep. & rec. 2002-02-004)

(a) Concrete Surfacing of Private Driveways. No concrete surfacing shall be installed on a private driveway closer than 3' from the hard surface on the road right-of-way. If for any reason any portion of the driveway in the town right-of-way would need replacing, the town shall not be responsible for the cost of the repair or the replacement. No concrete surface driveway shall be installed on any private driveway until a permit has been obtained from the Building Inspector and shall indicate the width and length of such driveway to be installed. The Building Inspector shall advise all owners of property of the requirement for such permit at the time when the application for a building permit for the construction of any residence or other building on the premises is applied for. The amount of said permit fee shall be set by the Town Board from time to time by resolution.

(b) Asphalt or Concrete Surfacing of Private Driveways within and Town Right-of-Ways. If for any reason any portion of a driveway that extends into the Town right-of-way needs to be constructed, repaired, replaced or resurfaced with asphalt ~~or concrete to comply with existing Town street grade~~, the Town shall not be responsible for the cost of the construction, repair, replacement or resurfacing. Concrete driveways shall not extend any closer than three (3) feet to the edge of the paved road. No ~~concrete asphalt~~ construction, repair, replacement or resurfacing shall be installed until an application has been submitted ~~and approved to by~~ the Town Highway Superintendent. After an application has been approved by the Town Highway Superintendent, the property owner ~~shall~~may contract with a private contractor for the asphalt construction, repair, replacement or resurfacing, ~~or the property owner may elect to use the asphaltting service of the Town. If the property owner elects to use the asphaltting service of the Town, the property owner shall, prior to any construction, deposit a fee equal to the~~

~~estimated time, materials and administrative costs of the asphalt construction, repair, replacement or resurfacing. After the asphalt construction, repair, replacement or resurfacing has been completed by the Town, the property owner shall be billed by the Town. Any amount owed by the property owner which is over and above the amount of the property owner's deposit shall be paid within 30 days. If the amount is not paid to the Town Treasurer on or before November 1, the Town shall have the amount owed entered on the tax roll as a special tax against the property. The Town shall pay to the property owner any amount which represents the difference between the deposit of the property owner and the actual costs of the asphalt construction, repair, replacement or resurfacing which is lower than the property owner's deposit.~~

(5) STREET GRADE. (Cr. #88-200) Every building hereafter erected, structurally altered or relocated shall be located on an improved street at a grade approved by the Building Inspector as being in satisfactory relationship with the established grades, if any, and, if not, with existing street grade, with particular consideration for proper drainage and safe vehicular access. Safe vehicular access is defined as a paved driveway of sufficient width and adequate horizontal alignment to accommodate emergency vehicles and a slope not to exceed 12% at any such point. Driveways shall be graded and graveled before construction commences. Cases in question may be referred to the Plan Commission by the Building Inspector.

(6) FINANCIAL GUARANTEES REQUIRED FOR REPAIR OF CURB AND GUTTERS (rep & rec. 17-626)

(a) Whenever a building permit is issued in an area where curb and gutter sections exist, the financial guarantee herein provided in subsection (3) above shall be required. This guarantee shall insure any necessary repairs to the curb and gutter section which may be damaged as a result of the construction activities authorized by the building permit.

(b) The Highway Superintendent shall make an inspection of the curb and gutter adjacent to the premises after an occupancy permit has been granted by the Building Inspector. Return of the financial guarantee shall be as subsection (c) below.

(c) If there is any damage to the curb and gutter sections as a result of the authorized construction activities, the damage shall be repaired by the Town and the cost thereof billed to the owner. If such bill is not paid within 30 days, the amount thereof shall be charged to the financial guarantee provided by the owner and the balance thereof shall be released by the Town to the property owner.

SECTION 2: Chapter 8 of the Town of Delafield Town Code entitled "Public Works", Section 8.03 entitled "Excavation in Public Right-of-Way", Subsection 2 entitled "Financial Requirements", Subsection a entitled "Performance Bond" is hereby repealed and re-created as follows:

(2) FINANCIAL REQUIREMENTS.

(a) Performance Bond. A performance bond binding the applicant, as principal, and a separate surety licensed to do business in this State, as surety, to the Town in an amount as set forth from time to time by resolution of the Town Board, the condition voiding the bond being that the applicant will perform and fully complete in a ~~workmanlike~~ approved by the Town Highway Superintendent, all work for which any highway and street opening permit is issued during the term of the bond in accordance with the provisions of this chapter and all other laws of any sort, and within the time prescribed by the Town Highway Superintendent. In addition, such bond shall provide that the applicant will backfill, maintain and restore the surface of any Town highway, Town maintained highway, street,

SECTION 3: Chapter 8 of the Town of Delafield Town Code entitled “Public Works”, Section 8.03 entitled “Excavation in Public Right-of-Way”, Subsection 3 entitled “Specifications for Highway and Street Openings”, Subsection d is hereby repealed and re-created as follows:

- (d) When any excavation is made in an existing or proposed pavement or driveway, or within 5' of the edge thereof, all excavated material must be removed and the excavation backfilled with slurry to 4-inches below the surface of the pavement in a manner approved by the Town Highway Superintendent. The top 4-inches shall be asphalt pavement conforming to specifications in this Chapter to within 5" of the surface within 1 1/2" maximum crushed gravel containing at least 60% crushed stone. Gradation of the gravel backfill shall conform to the applicable standards of the State Department of Transportation. Any C-concrete pavement shall be replaced in kind. Concrete shall meet the following specifications:

Minimum cement content - sacks per cubic yard	6.0
Compressive strength after 28 days cured	3,500 psi
Maximum amount of water per sack of cement	6.0 gallons
Size of coarse aggregate required	No. 1 plus No. 2
Slump	1 Inch - 3 Inches
Air Content	4.5% - 7.5%
<u>Admixtures (including flyash) shall NOT be allowed.</u>	

Any tunnels shall be backfilled ~~with 4 1/2 bag mix concrete~~ in a manner approved by the Town Highway Superintendent and Town Engineer. ~~Restoration in streets surfaced with bituminous concrete pavement shall conform to specifications on file in the office of the Town Clerk.~~

SECTION 4: Chapter 8 of the Town of Delafield Town Code entitled “Public Works”, Section 8.04 entitled “Heavy or Injurious Vehicles Restricted” is hereby repealed and re-created as follows:

8.04 HEAVY OR INJURIOUS VEHICLES RESTRICTED

No machine having lugged wheels or metal tracks or weighing more than 3 tons shall be driven or operated upon or along any street, alley or public place in the Town unless ~~a~~ permission therefore shall first be ~~is~~ secured from the Town Highway Superintendent, which ~~permit~~ shall specify the route to be taken by such machine and it shall be unlawful to deviate from such route. The Town Highway Superintendent may require the removal from any machine of any flanges, cleats, or other removable parts which could damage the streets, and also require, whenever in his judgment it is necessary that planks, plywood, plywood, plates or other sufficient protection for the streets be provided by the person driving or operating any such machine and be placed by such person on the street, and the machine shall be run upon such planks, plywood, plates or other protection when such requirement is made. Farm vehicles, such as tractors, combine harvesters, hay wagons, etc. shall be exempt from these requirements.

SECTION 5: Chapter 8 of the Town of Delafield Town Code entitled “Public Works”, section 8.05 entitled “Temporary Weight Restrictions” is hereby repealed and re-created as follows:

8.05 TEMPORARY WEIGHT RESTRICTIONS.

- (1) GENERAL. The Town may limit the use of any Town road, bridge or culvert at any time, to the use of motor vehicles having a gross vehicular weight, regardless of the number of axles,

of not more than 6 tons. Such restrictions may be imposed by the Town Highway Superintendent when in his judgment the use of any Town road, bridge or culvert would be damaged or destroyed by use for motor vehicles having a gross weight in excess of the limitation herein provided because of weakness of the roadbed, bridge or culvert due to deterioration or climate conditions or other special or temporary conditions.

(2) TEMPORARY LIMITS. Such temporary weight limitation shall be imposed by erecting signs on or along the Town road on which it is desired to impose the limitation sufficient to give reasonable notice that a temporary weight limitation is in effect and the nature of that limitation. Any temporary weight limitation as provided herein with reference to any bridge or culvert shall be imposed by erecting similar signs within 100' of each end of the bridge or culvert to which the weight limitation applies. All such temporary weight limitation signs shall comply with the rules of the State Department of Transportation.

(3) SPECIAL PERMIT. The Town may grant a special permit to the owner or operator of any motor vehicle having a gross weight in excess of the weight limitation herein imposed to operate the motor vehicle on any Town road while the weight limitation is in effect, if in his judgment an emergency condition exists which requires the use of such motor vehicle, and if the use of such motor vehicle would not damage the Town road on account of weather and street conditions at the time the permit is applied for. If such permit is issued, it shall be limited to the vehicle or vehicles described thereon and such permit shall name the street or streets upon which the vehicle or vehicles may travel, the gross vehicular weight allowed and the time that such permit shall be in effect. Applications for such permits shall be made to the Town Highway Superintendent.

SECTION 6: Chapter 8 of the Town of Delafield Town Code entitled "Public Works", Section 8.13 entitled "Standards for the Construction of Town Highways", Subsection 4 entitled "Construction Standards" is hereby repealed and re-created as follows:

(4) CONSTRUCTION STANDARDS. These construction standards and the previously listed design standards and required improvements shall apply to any party desiring acceptance by the Town of any road to be subsequently designated a Town highway and maintained by the Town. No road to be ultimately accepted as a Town highway and not shown on the Official Town Highway and Street Map shall be constructed without previous approval of the Town Board.

(a) The typical section for local residential Town roads is shown on Exhibits "A" ~~and "B"~~ and "C" at the end of this chapter. The typical section for all other roads shall be designated by the Town Engineer. (Am. #90-264)

(b) The Town Board shall require that profiles of roads to be constructed and accepted, be prepared by a Registered Professional Engineer ~~or Land Surveyor~~ in the State and be submitted to the Town Board for approval of the established grades on all of the proposed highways and drainage easements prior to preceding with any grading operations. ~~The Town Board shall determine the maximum and minimum slope in any cut to be made in connection with the construction of any Town highway, and the type and character and amount of fill necessary for the construction of any such highway, before any grading operations shall commence.~~

(c) Before commencing with any earth moving operations, the contractor shall obtain an erosion control and storm water management permit from Waukesha County Parks and Land Use Department, Land Resources Division. ~~construct sedimentation basins to eliminate erosion to downstream areas.~~ A drainage plan shall be submitted and shall consider the following: Temporary cover during grading operations; permanent grass and vegetative cover by use of stabilization materials, such as mulch, jute mat, excelsior, low growing plants, vines, and sod; construction of diversionary channel and terracing

access slopes; and leaving critical areas in undisturbed condition. The drainage plan shall be approved by the Town before the developer may proceed with any grading operations.

(d) Topsoil, peat, unstable material, all vegetative cover, stones, stumps, roots, and other deleterious materials shall be removed below the subgrade of the roads and replaced with sound fill materials placed and compacted to the satisfaction of the Town Highway Superintendent and Town Engineer. Any rock encountered shall be excavated to a point at least 20" below the finished grade of the roads. The contractor shall not proceed with the graveling operations until the subgrade has been checked for proper grade, proof-rolled and approved by the Town Engineer.

(e) After the subgrade has been approved, the contractor shall place a minimum of 10" of 1 ¼-inch dense graded base course in accordance with Section 305 of the crushed aggregate on the road bed in 2 lifts. The lower lift shall be 5" thick gradation no. 1 and the top lift shall be 5" thick gradation no. 2, conforming to §304.2.6, Standard Specifications for Road and Bridge Construction, Division of Highways, State Department of Transportation (State Specifications), most recent edition. Acceptable base materials shall be crushed stone or crushed gravel. In areas that are wet or seasonably wet, a minimum 6" layer of no. 2 stone shall be placed below the 10" base course layer at the direction of the Town Board. For areas that fail the proof roll, the contractor shall excavate to an elevation at which the contractor has determined that he/she can pass the proof roll, install a filter fabric (Type SR, Chapter 645 State Specifications), and fill the excavation with 3-inch dense graded base course and compact. The Town ~~Board~~ may require that the aggregate be tested at the owner's expense by an approved testing laboratory before being placed on the road. If additional material is required, in the opinion of the Town Highway Superintendent or Town Engineer~~Board~~, to stabilize the road, the same shall be furnished and applied to the satisfaction of the Town Highway Superintendent or Town Engineer~~Board~~ before acceptance, at no cost to the Town. (~~Am. #90-264~~) Shoulders, if required, shall be ¾-inch crushed stone or crushed gravel.

(f) After the aggregate has been placed and approved by the Town, 4-inches of bituminous concrete shall be placed in two lifts. The lower (binder) lift shall be a 2 1/24-inches" lift of bituminous concrete 3 LT 58-28 S placement gradation no. 2 shall be installed in accordance with ~~§4602~~ of the ~~Standard~~ Specifications. The Town may require that the asphalt course be cored to determine adequate thickness. The cost of these tests shall be paid by the developer. If the lower initial lift should be found to be less than 2 1/42-inches" in thickness, the average deficiency shall be determined by the Town Engineer and a proportionate increase be made in the final lift. The upper (surface) lift shall be 1 ¾-inches of bituminous concrete 5 LT 58-28 S, unless otherwise approved by the Town Highway Superintendent and Town Engineer. Other mix specifications may be used or required based on traffic analysis and site conditions, and shall be approved by the Town Highway Superintendent and Town Engineer. If the final thickness is found to be deficient, the deficiency shall be remedied by placing a lift over the entire roadway equal in thickness to such deficiency, but in no case less than 1-inch". (~~Am. #90-264~~)

(g) Curb and gutter that meets the requirements shown on Exhibit "D" shall be installed on the inside of all curvilinear roads and at all radii of intersections.

(h) Developer may install curb and gutter with storm sewer throughout the entirety of a subdivision, if approved by the Town Board, after recommendation from the Town Highway Superintendent and Town Engineer. Curb and gutter shall meet the requirements of Exhibit "D." Storm sewer shall meet the following standards:

- _____ Pipe: Reinforced Concrete Pipe
- _____ Catch Basins: File No. 29 (Green Book) with Neenah 3508 B Frame and Gate
- _____ Manholes: File Nos. 11 or 12 (Green Book)

Construction specifications shall be in accordance with the Standard Specifications for Sewer and Water Construction in Wisconsin, with Addendums (Green Book)

(g) When roadways intersect a collector street, County trunk highway, or State trunk highway, deceleration and acceleration lanes, flairs, tapers and/or increased radii may be required on one or both of the intersecting streets. The Town Engineer shall determine the location of these lanes, etc. These areas shall be graded, ~~stoned~~graveled, paved and landscaped as specified herein.

(h) All culverts shall be corrugated metal pipes or reinforced concrete pipe with standard end sections. ~~When~~

(i) Ditches and side slopes along roads and in easements shall be covered with a minimum of 4" of topsoil free of all stones, roots and other debris, graded, seeded and/or sodded, mulched, fertilized and maintained for a sufficient period to provide adequate grass cover prior to acceptance by the Town. Unless specifically altered by the Town Board, the following standards shall be follows:

<u>SLOPE OF DITCH</u>	<u>MINIMUM RESTORATION STANDARD</u>
<u>Less than 1.25%</u>	<u>No ditch is allowed to be less than 1.25% slope</u>
<u>1.25% to 2.00%</u>	<u>Ditch bottom shall be seeded and staked with jute matting or similar material.</u>
<u>2.00% to 4.00%</u>	<u>Ditch bottom shall be sodded and staked with jute matting or similar material</u>
<u>4.00% to 8.00%</u>	<u>Ditch bottom shall be sodded</u>
<u>Over 8.00%</u>	<u>Ditch bottom shall be paved.</u>

Town Engineer and Town Highway Superintendent may allow alternative restoration standards based on individual site conditions.

Slopes

~~Less than 0.50%~~

~~0.50% to 2.00%~~

~~2.00% to 4.00%~~

~~4.00% to 8.00%~~

~~Over 8.00%~~

~~Ditch bottom shall be seeded and staked with jute matting or similar material.~~

~~Ditch bottom shall be sodded and staked with jute matting or similar material.~~

~~Ditch bottom shall be paved or lined with stone rubble.~~

~~Ditch bottom shall be paved.~~

~~Ditch bottom may be seeded.~~

SECTION 7: Chapter 8 of the Town of Delafield Town Code entitled "Public Works", section 8.16 entitled "Uniform Address System", Subsection 4 entitled "System" is hereby

repealed and re-created as follows:

(4) SYSTEM. A system of invisible rectangular blocks shall be established as a central grid in the following manner conforming ~~with~~to the recommended uniform address system.

SECTION 8: Chapter 8 of the Town of Delafield Town Code entitled “Public Works”, section 8.16 entitled “Uniform Address System”, Subsection 7 entitled “Street Names” is hereby repealed and re-created as follows:

(7) STREET NAMES.

~~(a) Streets which are extensions of streets in Milwaukee County shall bear the name by which they are known in that county, excepting that directional prefixes, if any, shall be dropped. No directional prefix shall be used on any local street.~~

~~(b) All numerical street names shall be abandoned and other names substituted.~~

~~(ae)~~ A list shall be compiled by the Building Inspector of all existing street names in the Town and no future street shall be given a name which duplicates or approximates an existing name. Cooperation shall be sought with all towns and municipalities in the County to the end that duplication of street names shall be minimized.

~~(db)~~ The Town shall cooperate with neighboring towns, villages and cities to the end that streets which are continuous from one municipality or town to another municipality or town may have but one name when such single name would be desirable.

~~(ce)~~ The Town Board may accept or reject proposed names of new streets and, where there is clearly a conflict or duplication in existing names, may direct the changing of one or more such names so that conflict or duplication may be minimized. The Board, if it sees fit, may hold public hearings at which interested property owners may express their views concerning the naming or renaming of a street or streets.

SECTION 9: Chapter 8 of the Town of Delafield Town Code entitled “Public Works”, section 8.16 entitled “Uniform Address System”, Subsection 9 entitled “Installation of Numbers” is hereby repealed and re-created as follows:

(9) INSTALLATION OF NUMBERS.

(a) (Repeal & Rec. 99-484) When each residence and place of business has been assigned its respective number, the owner, occupant or agent shall install or cause to be installed those numbers on the premises along the side of the street on which the home sits; in a place clearly visible from the road, ~~no more than 25 feet from the edge of the road pavement; within 10 feet of either side edge of the driveway; and between 2' and 8' above the finished grade at the point of installation.~~

SECTION 10: SEVERABILITY.

The several sections of this ordinance are declared to be severable. If any section or portion thereof shall be declared by a court of competent jurisdiction to be invalid, unlawful or unenforceable, such decision shall apply only to the specific section or portion thereof directly specified in the decision, and shall not affect the validity of any other provisions, sections or portions thereof of the ordinance. The remainder of the ordinance shall remain in full force and effect. Any other ordinances whose terms are in conflict with the provisions of this ordinance

are hereby repealed as to those terms that conflict.

SECTION 11: EFFECTIVE DATE.

This ordinance shall take effect immediately upon passage and/or posting or publication as provided by law.

Dated this _____ day of _____, 2021.

TOWN OF DELAFIELD

Ron Troy, Town Chairman

ATTEST:

Dan Green, Town Administrator/Clerk

Published and/or posted this _____ day of _____, 2021.

INDEPENDENT CONTRACTOR AGREEMENT

This Independent Contractor Agreement (this "Agreement") is made effective as of September 01, 2021, by and between Town Of Delafield (the "Recipient"), of Delafield Wisconsin and Shawn's Deer Pick Up (the "Contractor"), of 1516 Pine St, South Milwaukee, Wisconsin 53172. In this Agreement, the party who is contracting to receive the services shall be referred to as "Recipient", and the party who will be providing the services shall be referred to as "Contractor."

1. DESCRIPTION OF SERVICES. Beginning on September 01, 2021, the Contractor will provide the 3-5 year terms. 2021-2024 Or 2021-2026 Please write in which you prefer. _____

Following services (collectively, the "Services"):

1-72Hr Window Deer Removal Service

All deer must be reported with gender and size if possible to make out to Deer pick up immediately upon report to plan accordingly.

2. PAYMENT FOR SERVICES. The Recipient will pay compensation to the Contractor for the Services in the amount of \$105 per deer. This compensation shall be payable in a lump sum End of The Month. No other fees and/or expenses will be paid to the Contractor, unless such fees and/or expenses have been approved in advance by the appropriate executive on behalf of the Recipient in writing. The Contractor shall be solely responsible for any and all taxes, Social Security contributions or payments, disability insurance, unemployment taxes, and other payroll type taxes applicable to such compensation.

3. TERM/TERMINATION. This Agreement may be terminated by either party upon 60 days' written notice to the other party.

A regular, ongoing relationship of indefinite term is not contemplated. The Recipient has no right to assign services to the Contractor other than as specifically contemplated by this Agreement. However, the parties may mutually agree that the Contractor shall perform other services for the Recipient, pursuant to the terms of this Agreement.

4. RELATIONSHIP OF PARTIES. It is understood by the parties that the Contractor is an independent contractor with respect to the Recipient, and not an employee of the Recipient. The Recipient will not provide fringe benefits, including health insurance benefits, paid vacation, or any other employee benefit, for the benefit of the Contractor.

It is contemplated that the relationship between the Contractor and the Recipient shall be a non-exclusive one. The Contractor also performs services for other organizations and/or individuals. The Recipient has no right to further inquire into the Contractor's other activities.

5. RECIPIENT'S CONTROL. The Recipient has no right or power to control or otherwise interfere with the Contractor's mode of effecting performance under this Agreement. The Recipient's only concern is the result of the Contractor's work, and not the means of accomplishing it. Except in extraordinary circumstances and when necessary, the Contractor shall perform the Services without direct supervision by the Recipient.

6. PROFESSIONAL CAPACITY. The Contractor is a professional who uses its own professional and business methods to perform services. The Contractor has not and will not receive training from the Recipient regarding how to perform the Services.

7. PERSONAL SERVICES NOT REQUIRED. The Contractor is not required to render the Services personally and may employ others to perform the Services on behalf of the Recipient without the Recipient's knowledge or consent. If the Contractor has assistants, it is the Contractor's responsibility to hire them and to

8. NO LOCATION ON PREMISES. The Contractor has no desk or other equipment either located at or furnished by the Recipient. Except to the extent that the Contractor works in a territory as defined by the Recipient, its services are not integrated into the mainstream of the Recipient's business.

9. NO SET WORK HOURS. The Contractor has no set hours of work. There is no requirement that the Contractor work full time or otherwise account for work hours.

10. EXPENSES PAID BY CONTRACTOR. The Contractor's business and travel expenses are to be paid by the Contractor and not by the Recipient.

11. CONFIDENTIALITY. Contractor may have had access to proprietary, private and/or otherwise confidential information ("Confidential Information") of the Recipient. Confidential Information shall mean all non-public information which constitutes, relates or refers to the operation of the business of the Recipient, including without limitation, all financial, investment, operational, personnel, sales, marketing, managerial and statistical information of the Recipient, and any and all trade secrets, customer lists, or pricing information of the Recipient. The nature of the information and the manner of disclosure are such that a reasonable person would understand it to be confidential. The Contractor will not at any time or in any manner, either directly or indirectly, use for the personal benefit of the Contractor, or divulge, disclose, or communicate in any manner any Confidential Information. The Contractor will protect such information and treat the Confidential Information as strictly confidential. This provision shall continue to be effective after the termination of this Agreement. Upon termination of this Agreement, the Contractor will return to the Recipient all Confidential Information, whether physical or electronic, and other items that were used, created, or controlled by the Contractor during the term of this Agreement.

This Agreement is in compliance with the Defend Trade Secrets Act and provides civil or criminal immunity to any individual for the disclosure of trade secrets: (i) made in confidence to a federal, state, or local government official, or to an attorney when the disclosure is to report suspected violations of the law; or (ii) in a complaint or other document filed in a lawsuit if made under seal.

12. INJURIES. The Contractor acknowledges the Contractor's obligation to obtain appropriate insurance coverage for the benefit of the Contractor (and the Contractor's employees, if any). The Contractor waives any rights to recovery from the Recipient for any injuries that the Contractor (and/or Contractor's employees) may sustain while performing services under this Agreement and that are a result of the negligence of the Contractor or the Contractor's employees. Contractor will provide the Recipient with a certificate naming the Recipient as an additional insured party.

13. NO RIGHT TO ACT AS AGENT. An "employer-employee" or "principal-agent" relationship is not created merely because (1) the Recipient has or retains the right to supervise or inspect the work as it progresses in order to ensure compliance with the terms of the contract or (2) the Recipient has or retains the right to stop work done improperly. The Contractor has no right to act as an agent for the Recipient and has an obligation to notify any involved parties that it is not an agent of the Recipient

14. ENTIRE AGREEMENT. This Agreement constitutes the entire contract between the parties. All terms and conditions contained in any other writings previously executed by the parties regarding the matters contemplated herein shall be deemed to be merged herein and superseded hereby. No modification of this Agreement shall be deemed effective unless in writing and signed by the parties.

15. WAIVER OF BREACH. The waiver by the Recipient of a breach of any provision of this Agreement by Contractor shall not operate or be construed as a waiver of any subsequent breach by Contractor.

16. SEVERABILITY. If any provision of this Agreement shall be held to be invalid or unenforceable for any reason, the remaining provisions shall continue to be valid and enforceable. If a court finds that any provision of this Agreement is invalid or unenforceable, but that by limiting such provision it would become valid and enforceable, then such provision shall be deemed to be written, construed, and enforced as so limited.

17. APPLICABLE LAW. This Agreement shall be governed by the laws of the State of Wisconsin.

18. SIGNATORIES. This Agreement shall be signed by _____ on behalf of Town Of Delafield and by Shawn Kreamsreiter on behalf of Shawn's Deer Pick Up. This Agreement is effective as of the date first above written.

CONTRACTOR:
Shawn's Deer Pick Up
Date:
Shawn Kreamsreiter

RECIPIENT:
Town Of Delafield
Date
By: